

# ULTIMATE KCET



## CRASH COURSE 2026

Chemistry

Lecture - 01

### Electrochemistry

By - Sreeja Ma'am

Physics Wallah





# Recap *of previous lecture*

- 1 Redox reaction

# Topics *to be covered*



## 1 Electrochemistry

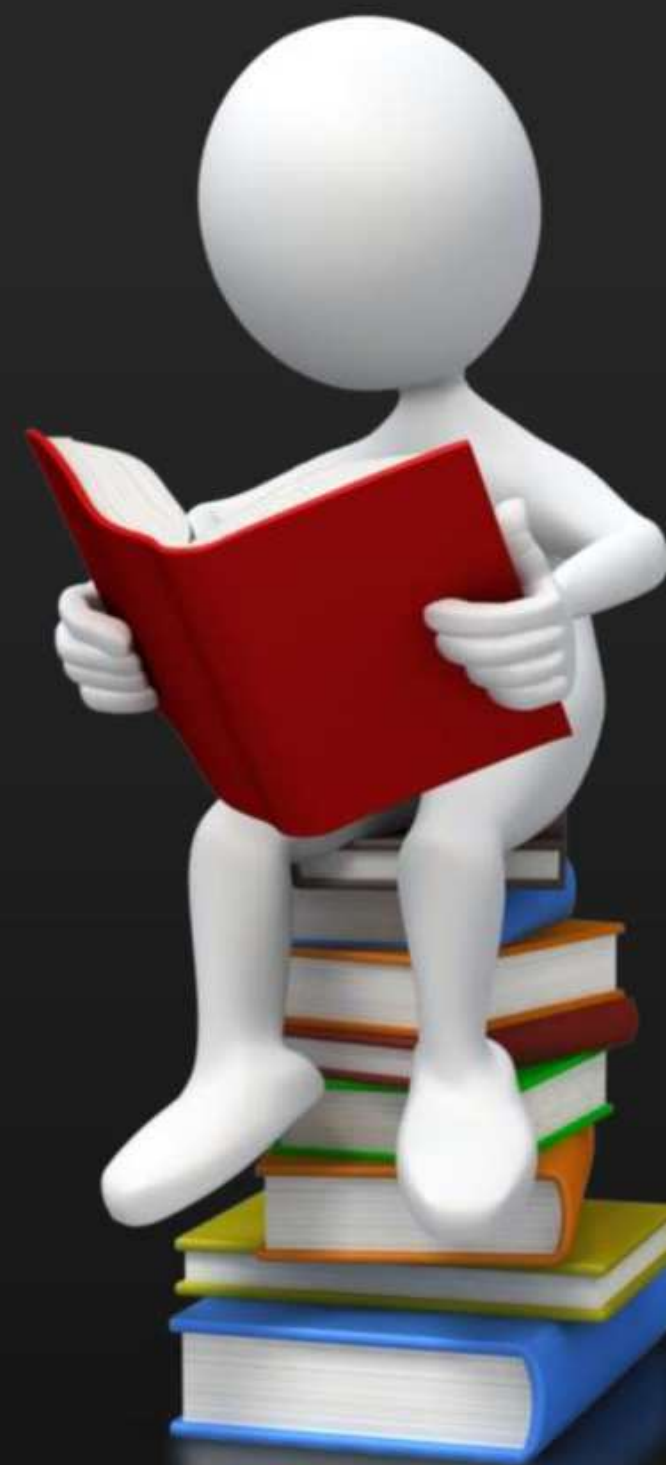

# Electrochemistry



$$[H^+] = [Cd]$$

Year	Topic	Number of questions
2025	Galvanic cell statement type, electronic conductance statement type, Faraday's law - 03	
2024	Faraday's first law – 02, Debye Onsager equation	03
2023	pH calculations, product of electrolysis – Brine solution, Nernst equation,	03
2022	Gibbs free energy and spontaneity, Molar conductance (02), Catalyst used in Fuel cell, Nernst equation	04
2021	Nernst equation, cell constant, equilibrium constant	03
2020	Debye Onsager equation, Equilibrium constant, Product of electrolysis – NaF	04
2019	Displacement reaction, Emf calculations, Product of electrolysis, Faradays first law of electrolysis	04
2018	Molar conductance/specific conductance, Conductor/Non conductor	03
2017	Product of electrolysis of Aq NaCl	01
2016	Galvanic cell – Oxidation/reduction Vs anode/cathode, secondary cell, Faraday's law of electrolysis	03



Spontaneous redox reaction

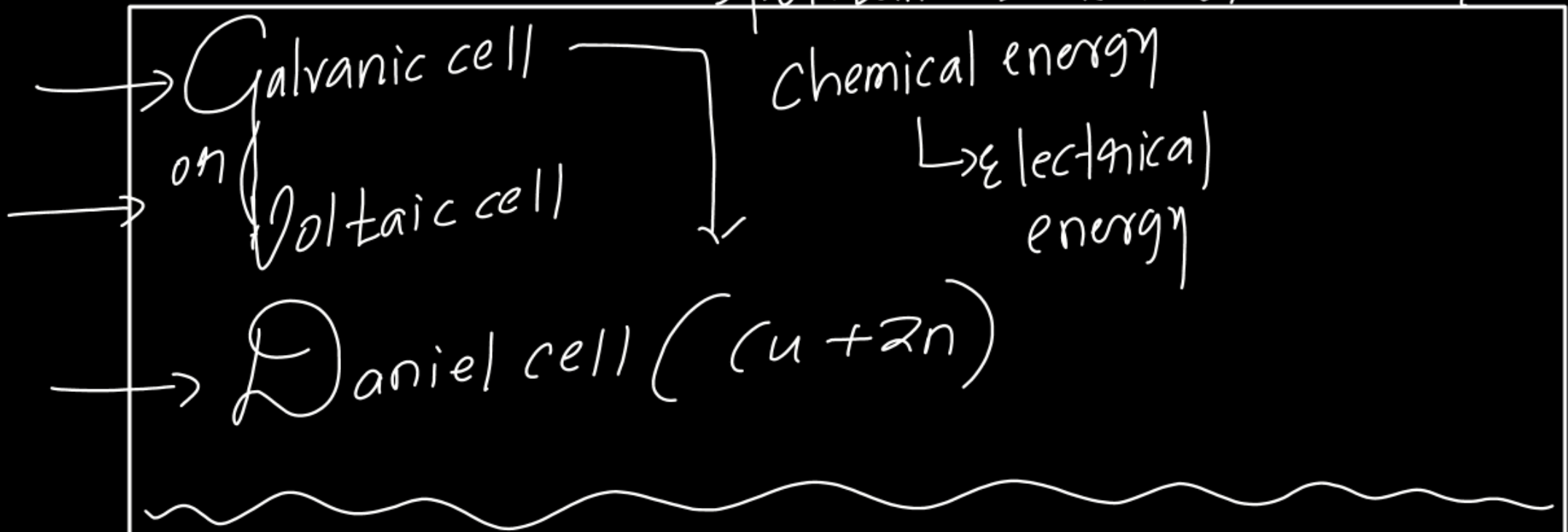

Device which converts electrical energy to nonspontaneous chemical energy is called  $\rightarrow$  Electrolytic cell.



$H_2S, SO_2$

$H_2O_2$

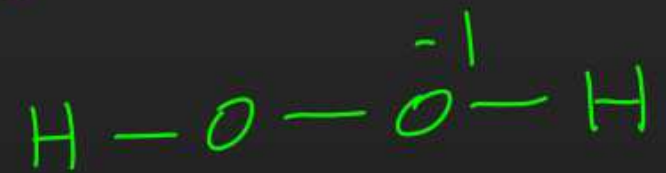

$H_2O$

$H^+ \text{ } \overset{\ominus}{O} \text{ } \overset{\ominus}{O} \text{ } \overset{\ominus}{O}$   
O.A  $\rightarrow$  oxidizing ability

2025

3. Match List-I with List-II

List-I (Types of redox reactions)	List-II (Examples)
a. Combination reaction <span style="color:red">iii</span>	i. $Cl_{2(g)} + 2Br_{(aq)}^- \rightarrow 2Cl_{(aq)}^- + Br_{2(l)}$
b. Decomposition reaction <span style="color:red">iv</span>	ii. $2H_2O_{2(aq)} \rightarrow 2H_2O_{(l)} + O_{2(g)}$
c. Displacement reaction <span style="color:red">i</span>	iii. $CH_{4(g)} + 2O_{2(g)} \xrightarrow{\Delta} CO_{2(g)} + 2H_2O_{(l)}$
d. Disproportionation reaction <span style="color:red">ii</span>	iv. $2H_2O_{(l)} \xrightarrow{\Delta} 2H_{2(g)} + O_{2(g)}$

Choose the correct answer from the options given below.

- (1) a-iv, b-iii, c-i, d-ii    (2) a-ii, b-i, c-iv, d-iii    ~~(3) a-iii, b-iv, c-i, d-ii~~    (4) a-iii, b-ii, c-i, d-iv

In the reaction between hydrogen sulphide and acidified permanganate solution,

- (1)  $H_2S$  is reduced to S,  $MnO_4^-$  is oxidised to  $Mn^{2+}$   
 (2)  $H_2S$  is oxidised to  $SO_2$ ,  $MnO_4^-$  is reduced to  $MnO_2$   
 (3)  $H_2S$  is reduced to  $SO_2$ ,  $MnO_4^-$  is oxidised to  $Mn^{2+}$   
 (4)  $H_2S$  is oxidised to S,  $MnO_4^-$  is reduced to  $Mn^{2+}$

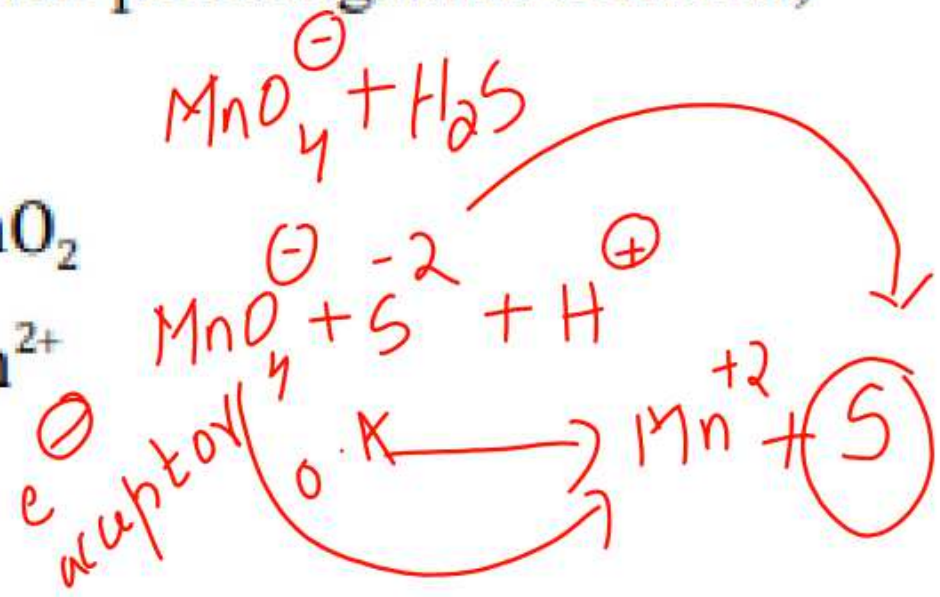

- $F^-$   
 $Cl^-$   
 $Br^-$   
 $I^-$

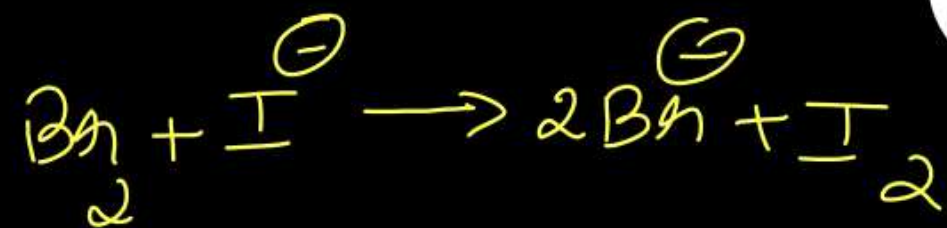

Halogens

Halide ions

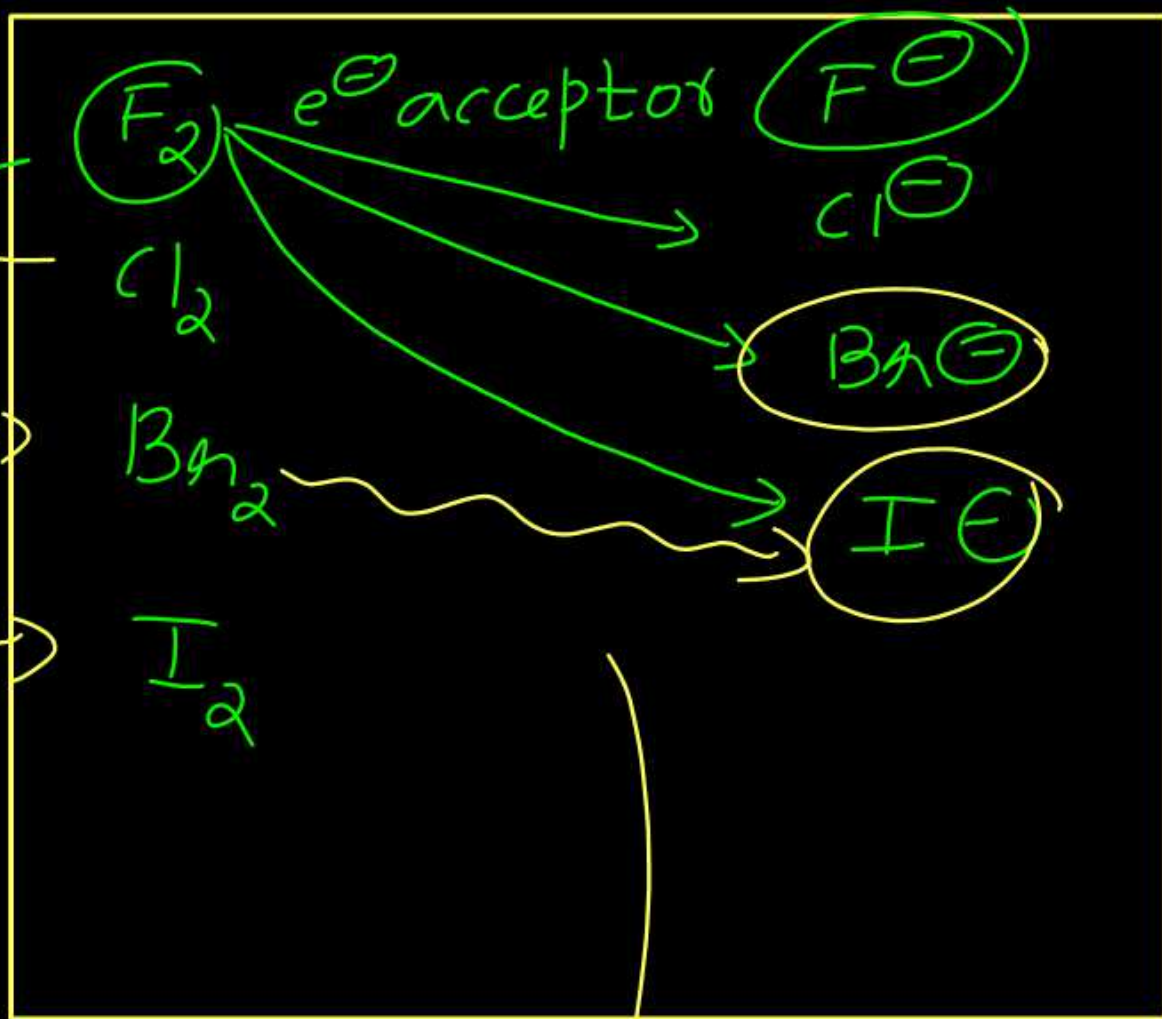

Strong  
O.A.  
e<sup>-</sup> acceptors

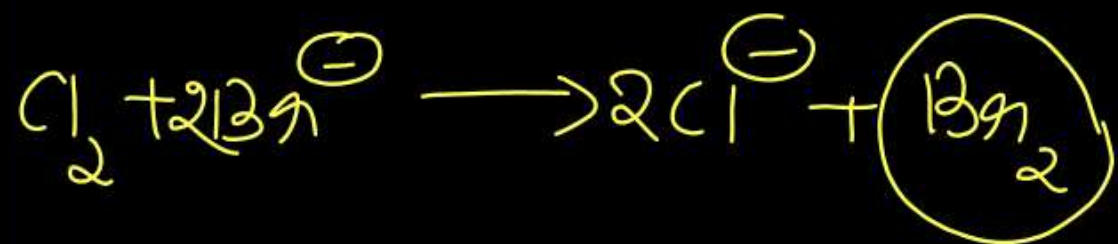

$$\Pi_{N_2} = 7.10 \times 10$$

49. The correct statement/s about Galvanic cell is/are

- (a) Current flows from cathode to anode
- (b) Anode is positive terminal
- (c) If  $E_{\text{cell}} < 0$ , then it is spontaneous reaction
- (d) Cathode is positive terminal

(1) a and b only

(2) a, b and c

~~(3) a and d only~~

(4) b only

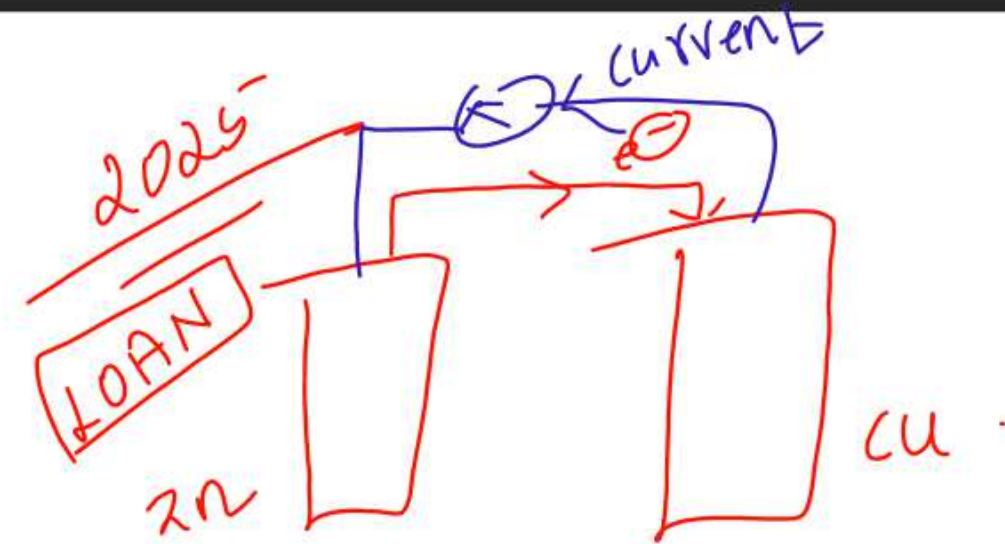

50. The electronic conductance depends on

- (1) Nature of electrolyte added  $\rightarrow$  ionic conductance
- (2) The number of valence electrons per atom
- (3) Concentration of the electrolyte  $\leftarrow$  ionic conductance
- (4) Size of the ions

Ans. 2

$$\Delta G^\circ = -nFE^\circ$$

$$E^\circ = +ve$$

→ Spontaneous

51. For a given half cell,  $\text{Al}^{3+} + 3e^- \rightarrow \text{Al}$  on increasing of aluminium ion, the electrode potential will  
 (1) Decrease (2) No change (3) First increase then decrease (4) Increase

Ans. 4

Solution :  $\text{Al}^{3+} + 3e^- \rightarrow \text{Al}(s)$

$$E_{\text{Red}} = E_{\text{Red}}^{\circ} - \frac{0.0591}{3} \log \frac{[\text{Al}(s)]}{[\text{Al}^{3+}]}$$

*cell cell*

$$E_{\text{Red}} = E_{\text{Red}}^{\circ} - \frac{0.0591}{3} \log \frac{1}{[\text{Al}^{3+}]} \quad [\text{Since active mass of solid} = 1]$$

$$E_{\text{Red}} = E_{\text{Red}}^{\circ} + \frac{0.0591}{3} \log [\text{Al}^{3+}]$$

So  $E_{\text{Red}} \propto [\text{Al}^{3+}] \propto \text{conc}^n \text{ of } \text{Al}^{3+}$

$$\log \frac{1}{[\text{Al}^{3+}]} = -\log [\text{Al}^{3+}]$$

52. Match the following select the correct option for the quantity of electricity, in  $\text{Cmol}^{-1}$  required to deposit various metals at cathode

$96,500 \text{ C} \approx 1 \text{ kAc}$

	List - I		List- II
a	$\text{Ag}^+$ 1F	i	<u><math>386000 \text{ Cmol}^{-1}</math></u>
b	$\text{Mg}^{2+}$ 2F	ii	<u><math>289500 \text{ Cmol}^{-1}</math></u>
c	$\text{Al}^{3+}$ 3F	iii	<u><math>96500 \text{ Cmol}^{-1}</math></u> 1F
d	$\text{Ti}^{4+}$ 4F	iv	<u><math>193000 \text{ Cmol}^{-1}</math></u>

2025

- (1) a - ii, b - i, c - iv, d - iii  
 (3) a - iv, b - iii, c - i, d - ii

- ~~(2) a - iii, b - iv, c - ii, d - i~~  
 (4) a - i, b - ii, c - iii, d - iv

# Daniell cell

LOAN

Left oxidation  
Anode -ve  
RRCP  
[O]  
[R]

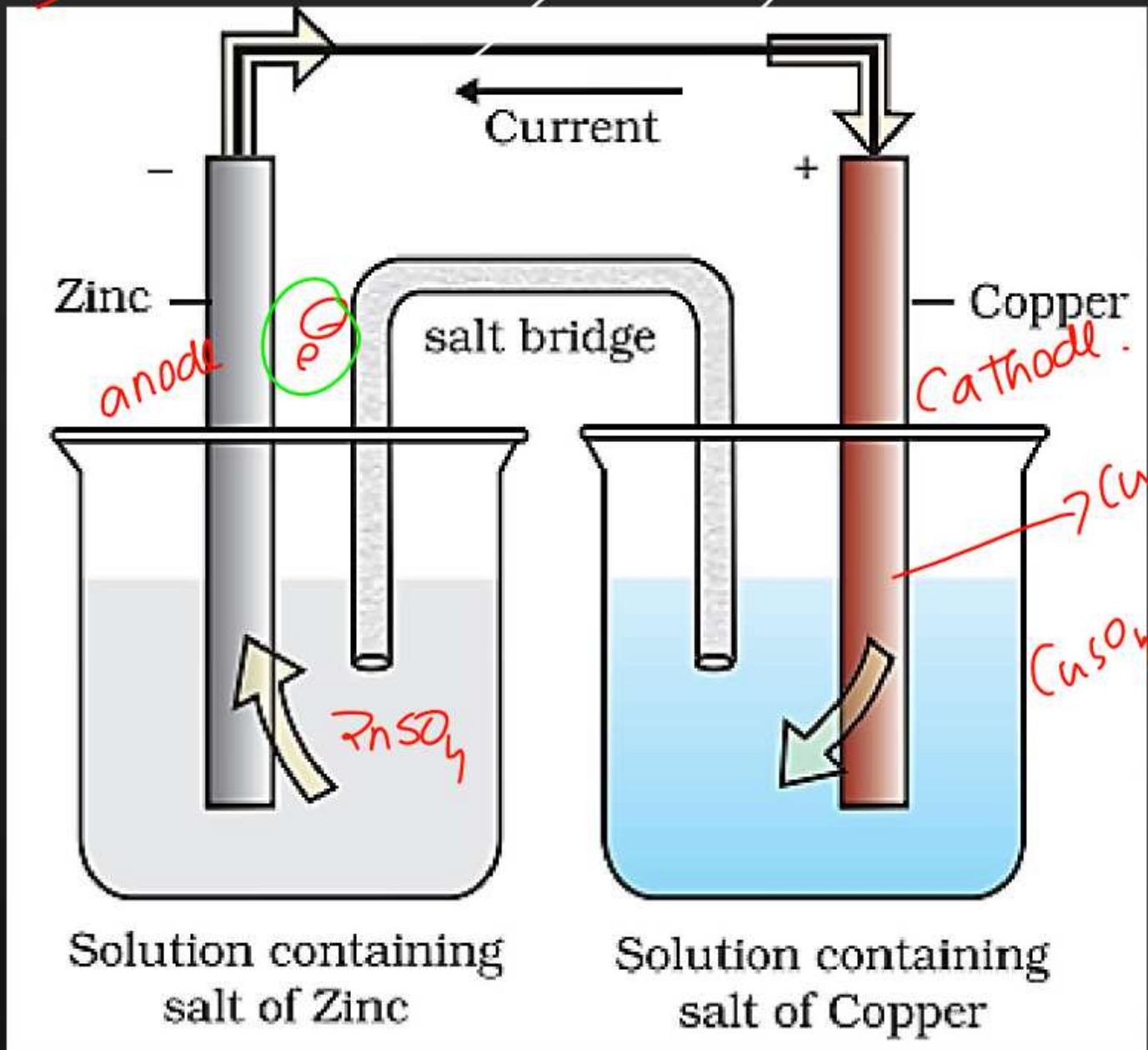
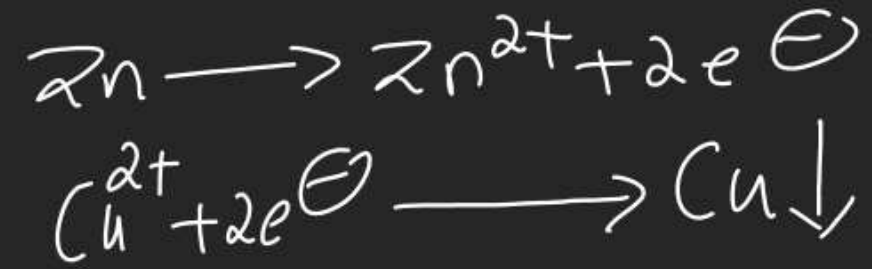

- This cell converts the chemical energy liberated during the redox reaction to electrical energy and has an electrical potential equal to 1.1 V.
- when concentration of  $\text{Zn}^{2+}$  and  $\text{Cu}^{2+}$  ions is unity. Such a device is called a galvanic or a voltaic cell

$$EMF = E^{\circ}_{\text{cathode}} - E^{\circ}_{\text{anode}}$$

+ve value

$e^-$   
anode  $\rightarrow$  cathode  
Current -  
cathode  $\rightarrow$  anode

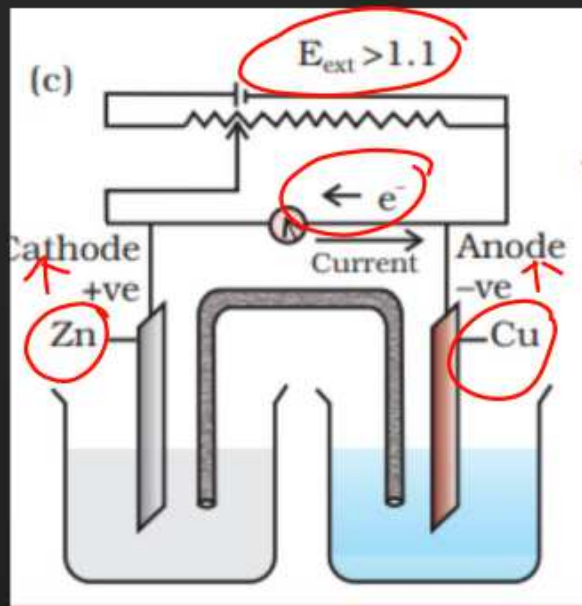

When  $E_{ext} > 1.1 \text{ V}$

- (i) Electrons flow from Cu to Zn and current flows from Zn to Cu.
- (ii) Zinc is deposited at the zinc electrode and copper dissolves at copper electrode.

$E^0 = 1.1 \text{ V}$

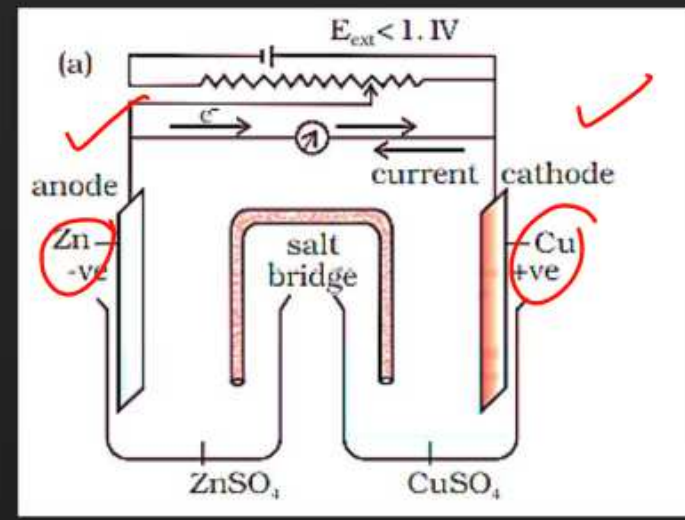

When  $E_{ext} < 1.1 \text{ V}$

- (i) Electrons flow from Zn rod to Cu rod hence current flows from Cu to Zn.
- (ii) Zn dissolves at anode and copper deposits at cathode.

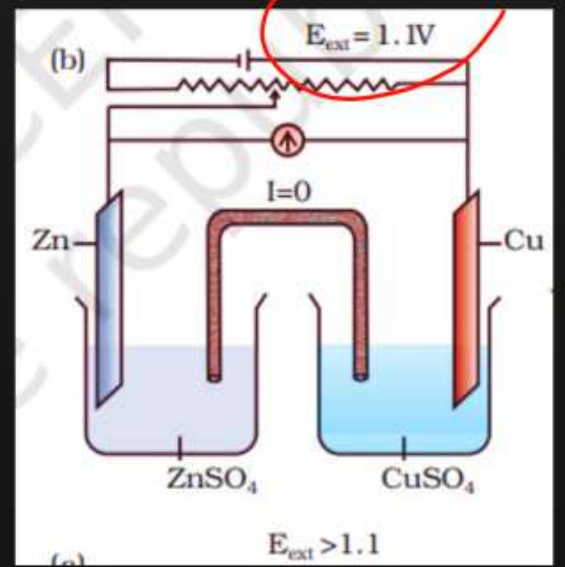

When  $E_{ext} = 1.1 \text{ V}$

- (i) No flow of electrons or current.
- (ii) No chemical reaction.

(c)  $E_{ext} > 1.1$

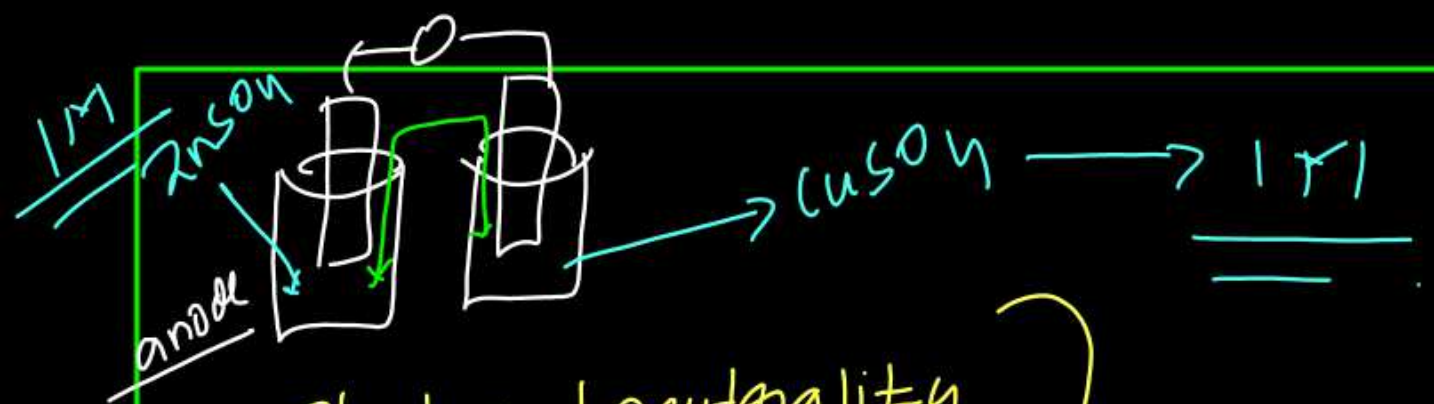

→ Electrical neutrality  
 → inner circuit connection } salt bridge function

→ Cell potential →  $E^{\circ} = E^{\circ}_{\text{RHS}} - E^{\circ}_{\text{LHS}}$   
 EMF →  $E^{\circ} = E^{\circ}_{\text{cathode}} - E^{\circ}_{\text{anode}}$

→  $E_{\text{cell}} = E^{\circ}_{\text{cell}} - \frac{0.0591}{n} \log \frac{[\text{anode ion}]}{[\text{cathode ion}]}$

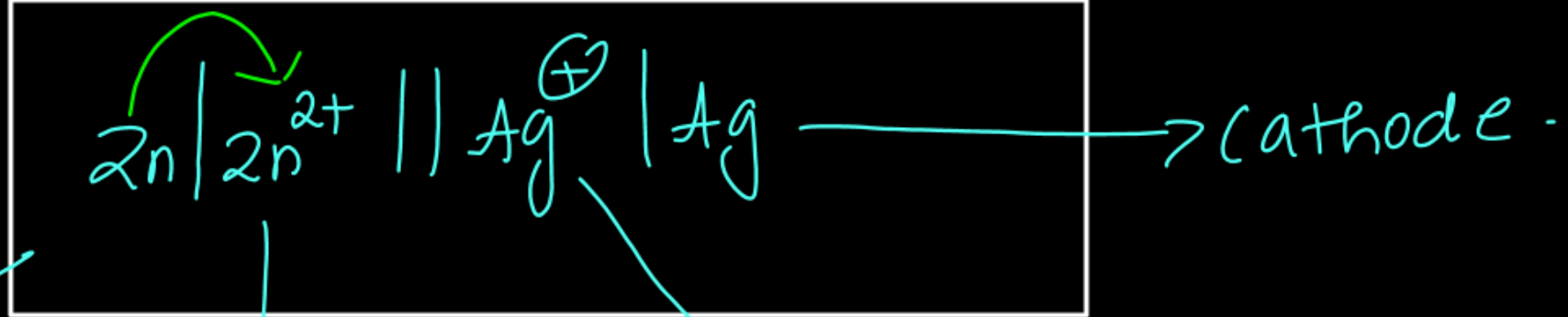

anode

anode electrolyte

Cathode electrolyte

$$E_{\text{cell}} = E_{\text{cell}}^{\circ} - \frac{0.059}{n} \log \frac{[\text{anode ion}]}{[\text{cathode ion}]}$$

$$E_{\text{cell}} = E_{\text{cell}}^{\circ} - \frac{0.059}{2} \log \frac{[\text{Zn}^{2+}]}{[\text{Ag}^{\oplus}]}$$

$E_{\text{cell}}$  is maximum when cathode ion conc is max.

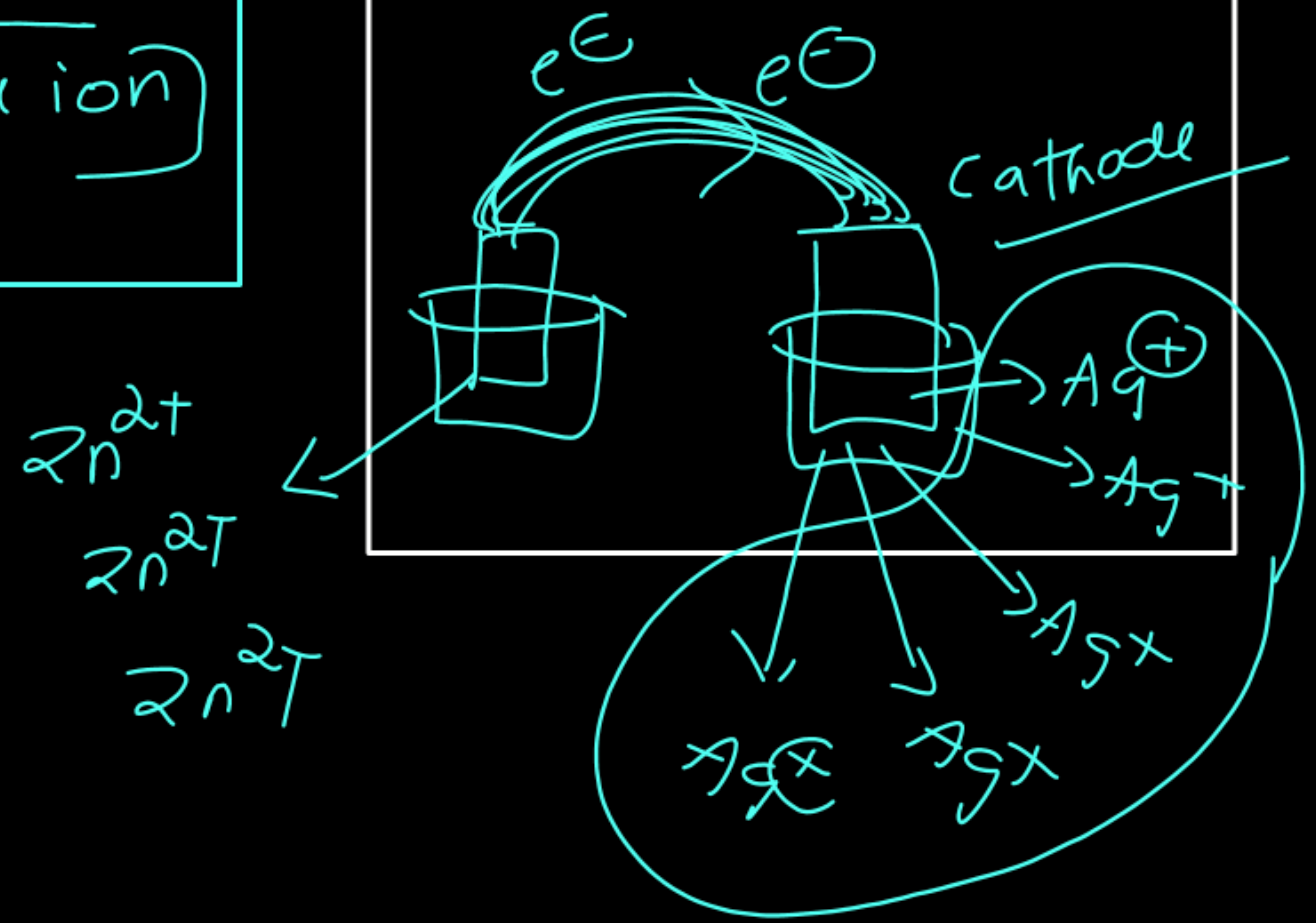



$$E_{RP} = E_{cell}^{\circ} - \frac{0.0591}{2} \log \frac{[2n](s)}{[2n^{2+}]}$$

$$E_{RP} = E_{cell}^{\circ} - \frac{0.0591}{n} \log \frac{[Reductant]}{[Oxidant]}$$

$$E_{RP} = E_{cell}^{\circ} - \frac{0.0591}{2} \log \frac{1}{[2n^{2+}]}$$

### Oxidation

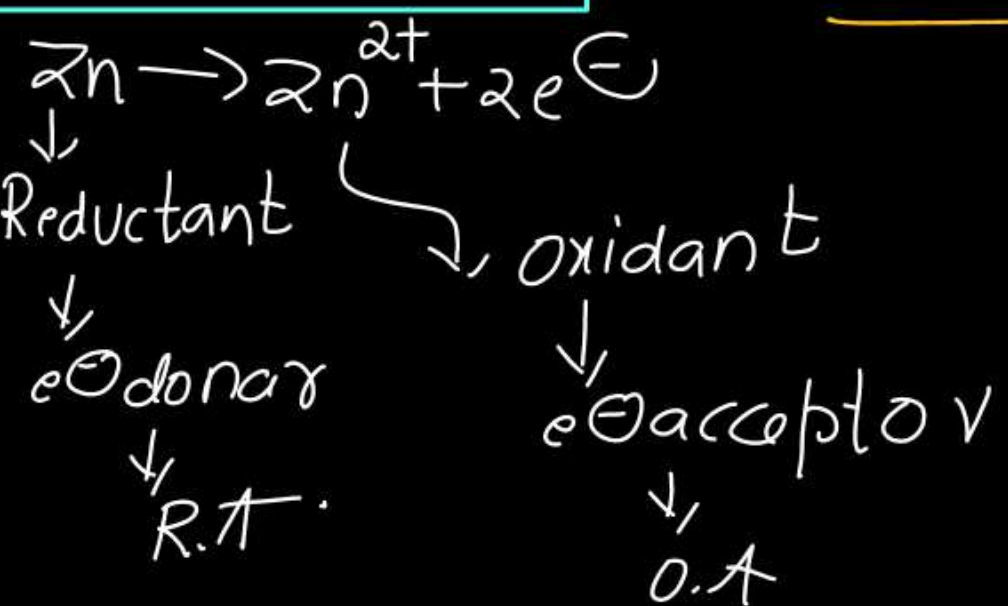

$$\begin{aligned}
 E_{op} &= E_{op}^{\circ} - \frac{0.0591}{2} \log \frac{[2n^{2+}]}{[2n]} \\
 &= E_{op}^{\circ} - \frac{0.0591}{n} \log \frac{[Oxidant]}{[Reductant]}
 \end{aligned}$$

Oxidation potential



→  $E_{cell}$  for diff. conc.

$$E_{cell}^{\circ} = E_{cathode}^{\circ} - E_{anode}^{\circ}$$

$$\Delta G^{\circ} = -2.303 nRT \log K_c$$

$$E_{cell} = +ve$$

spontaneous → anode to cathode →  $e^{-}$  movement.

$$E_{cell} = \text{zero at equilibrium}$$

### Gibb's free energy

$$\Delta G^{\circ} = -nFE^{\circ}$$

$n$  → no. of moles of  $e^{-}$  involved in redox reaction

$$E_{cell}^{\circ} = \frac{0.0591}{n} \log K_c$$



$$K_c = \frac{[C]^c [D]^d}{[A]^a [B]^b}$$

$\Delta G^{\circ} = -ve$  → for any redox reactions to be spontaneous.

$$E^{\circ} = E_{RHS}^{\circ} - E_{LHS}^{\circ} = E_{cathode}^{\circ} - E_{anode}^{\circ}$$



# Electrolytic cell

$$R \propto \frac{l}{a}$$

Ohm  
 $\Omega$

$$R = \frac{1}{G}$$

$$G = \frac{1}{R}$$

$G$  = conductance

$R$  = Resistance

$$R = \rho \frac{l}{a}$$

$\rho$  → resistivity  
specific  
resistance

$$\rho = R \times \frac{a}{l}$$

$$\rho = \text{ohm} \frac{\text{m}^2}{\text{m}}$$

$$\rho = \text{ohm m}$$

Kappa → specific conductance  
[conductivity]

$$K = \frac{1}{\rho}$$

$$K = \frac{1}{R \times \frac{a}{l}}$$

$$K = \frac{1}{R} \times \frac{l}{a}$$

$$K = \frac{1}{R} \times G^*$$

$$K = G_1 G_1^*$$

unit for K

$$K = \text{ohm}^{-1} \text{m}^{-1}$$

$$\text{ohm}^{-1} \text{cm}^{-1}$$

$$\text{S cm}^{-1} \checkmark$$

$$\text{S m}^{-1}$$

## Molar conductance

$$\Lambda_m = \frac{1000 \times K}{C}$$

$K$  → specific  
conductance

$C$  → concentration

$$\Lambda_m = \frac{1000 \times \text{S cm}^{-1}}{\text{mol cm}^{-3}}$$

$$\Lambda_m = \text{S cm}^2 \text{mol}^{-1}$$

$$C = \text{mol dm}^{-3}$$

$$C = \text{mol L}^{-1}$$

$$C = \text{mol cm}^{-3}$$

$$\text{cm}^2$$

# Kohlrausch's law

$$\Lambda_m^\ominus = x \lambda_m^\oplus + y \lambda_m^\ominus$$

$$\alpha = \frac{\Lambda_m^c}{\Lambda_m^\ominus}$$

$$[H^+] = c\alpha$$

$$K_c = \frac{c\alpha^2}{1-\alpha}$$

$$pH = -\log [H^+]$$

$$pH = \log \frac{1}{[H^+]}$$

# Faraday's first law

$$W \propto Q$$

$$W \propto It$$

$$W = ZIt$$

$$Q = It \rightarrow \text{As.}$$

Z → electrochemical equivalent

→ amount of substance deposited when 1 ampere current is passed for 1 second.

$$Z = \frac{\text{Equivalent weight}}{96,500}$$

$$\text{Equivalent weight} = \frac{\text{Atomic mass}}{\text{charge}}$$

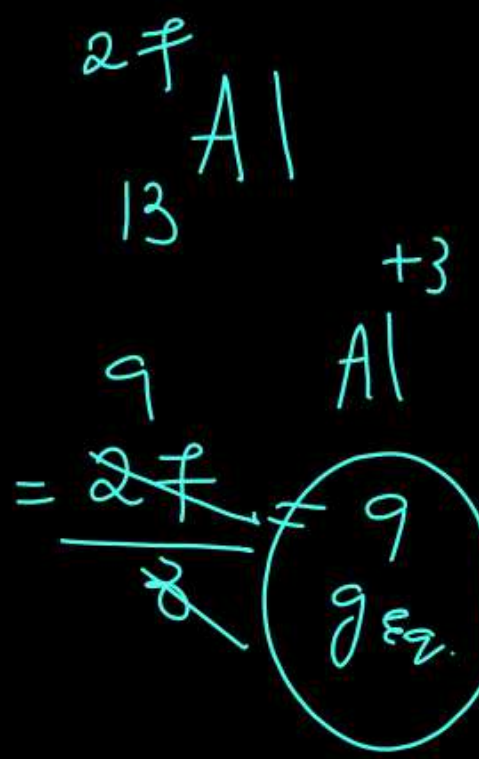



Equivalent weight

of Ag =  $\frac{108}{1} = 108 \text{ g eqwt}$

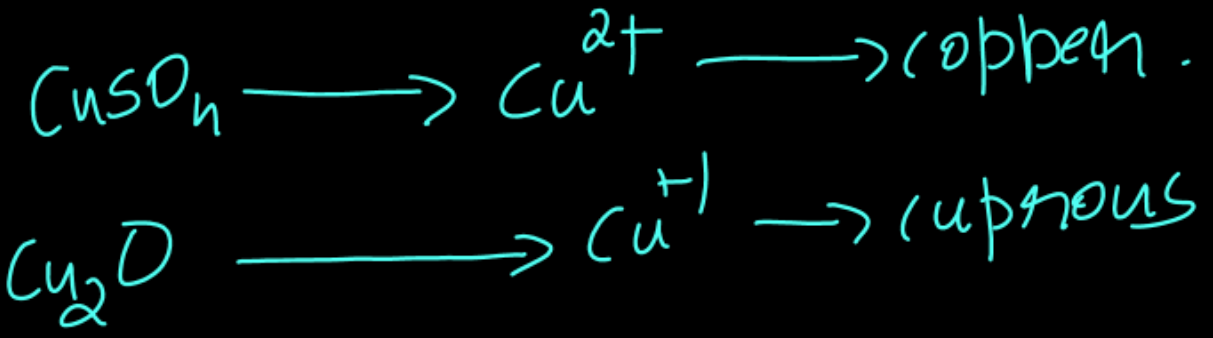
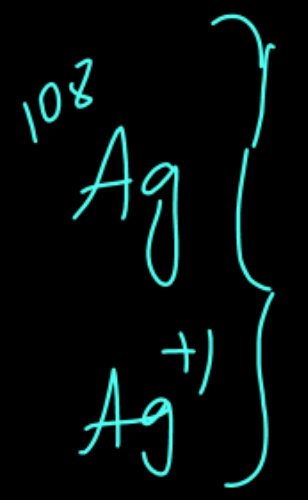

Eq. wt of  $\text{Cu}^{2+} = \frac{63.5}{2} = 31.75$

63.5  
Cu

Eq. wt of oxygen

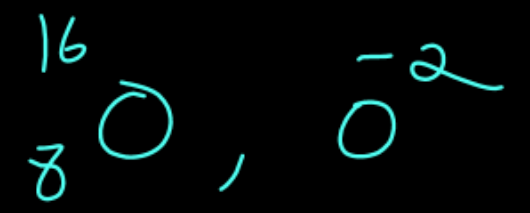

Eq. wt =  $\frac{16}{8} = 8 \text{ g eq. wt}$

Faraday's second law

$\frac{W_1}{W_2} = \frac{E_1}{E_2}$

Same Q  $\rightarrow \text{CuSO}_4$   
 $\rightarrow 2\text{CuSO}_4$

Stronger oxidizing agent



Weaker oxidizing agent

Cathode

anode

$F_2(g) + 2 e^-$	$\longrightarrow 2 F^-(aq)$	2.87
$H_2O_2(aq) + 2 H^+(aq) + 2 e^-$	$\longrightarrow 2 H_2O(l)$	1.78
$MnO_4^-(aq) + 8 H^+(aq) + 5 e^-$	$\longrightarrow Mn^{2+}(aq) + 4 H_2O(l)$	1.51
$Cl_2(g) + 2 e^-$	$\longrightarrow 2 Cl^-(aq)$	1.36
$Cr_2O_7^{2-}(aq) + 14 H^+(aq) + 6 e^-$	$\longrightarrow 2 Cr^{3+}(aq) + 7 H_2O(l)$	1.33
$O_2(g) + 4 H^+(aq) + 4 e^-$	$\longrightarrow 2 H_2O(l)$	1.23
$Br_2(l) + 2 e^-$	$\longrightarrow 2 Br^-(aq)$	1.09
$Ag^+(aq) + e^-$	$\longrightarrow Ag(s)$	0.80
$Fe^{3+}(aq) + e^-$	$\longrightarrow Fe^{2+}(aq)$	0.77
$O_2(g) + 2 H^+(aq) + 2 e^-$	$\longrightarrow H_2O_2(aq)$	0.70
$I_2(s) + 2 e^-$	$\longrightarrow 2 I^-(aq)$	0.54
$O_2(g) + 2 H_2O(l) + 4 e^-$	$\longrightarrow 4 OH^-(aq)$	0.40
$Cu^{2+}(aq) + 2 e^-$	$\longrightarrow Cu(s)$	0.34
$Sn^{4+}(aq) + 2 e^-$	$\longrightarrow Sn^{2+}(aq)$	0.15
$2 H^+(aq) + 2 e^-$	$\longrightarrow H_2(g)$	0
$Pb^{2+}(aq) + 2 e^-$	$\longrightarrow Pb(s)$	-0.13
$Ni^{2+}(aq) + 2 e^-$	$\longrightarrow Ni(s)$	-0.26
$Cd^{2+}(aq) + 2 e^-$	$\longrightarrow Cd(s)$	-0.40
$Fe^{2+}(aq) + 2 e^-$	$\longrightarrow Fe(s)$	-0.45
$Zn^{2+}(aq) + 2 e^-$	$\longrightarrow Zn(s)$	-0.76
$2 H_2O(l) + 2 e^-$	$\longrightarrow H_2(g) + 2 OH^-(aq)$	-0.83
$Al^{3+}(aq) + 3 e^-$	$\longrightarrow Al(s)$	-1.66
$Mg^{2+}(aq) + 2 e^-$	$\longrightarrow Mg(s)$	-2.37
$Na^+(aq) + e^-$	$\longrightarrow Na(s)$	-2.71
$Li^+(aq) + e^-$	$\longrightarrow Li(s)$	-3.04

$e^-$  acceptor

O.A

Cathode

R.A

Anode

$e^-$  donors

Stronger reducing agent

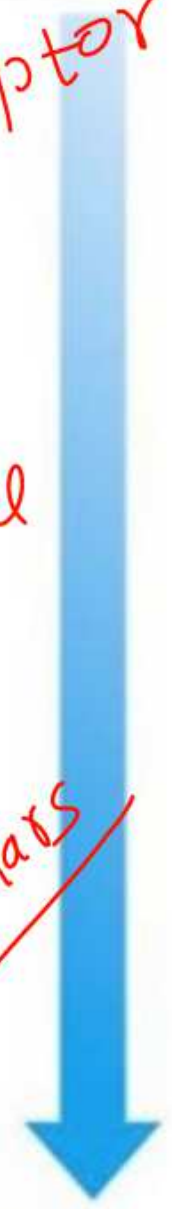

## Representation of Electrochemical Cell

An electrochemical cell is represented in a manner as illustrated below for the Daniell cell.

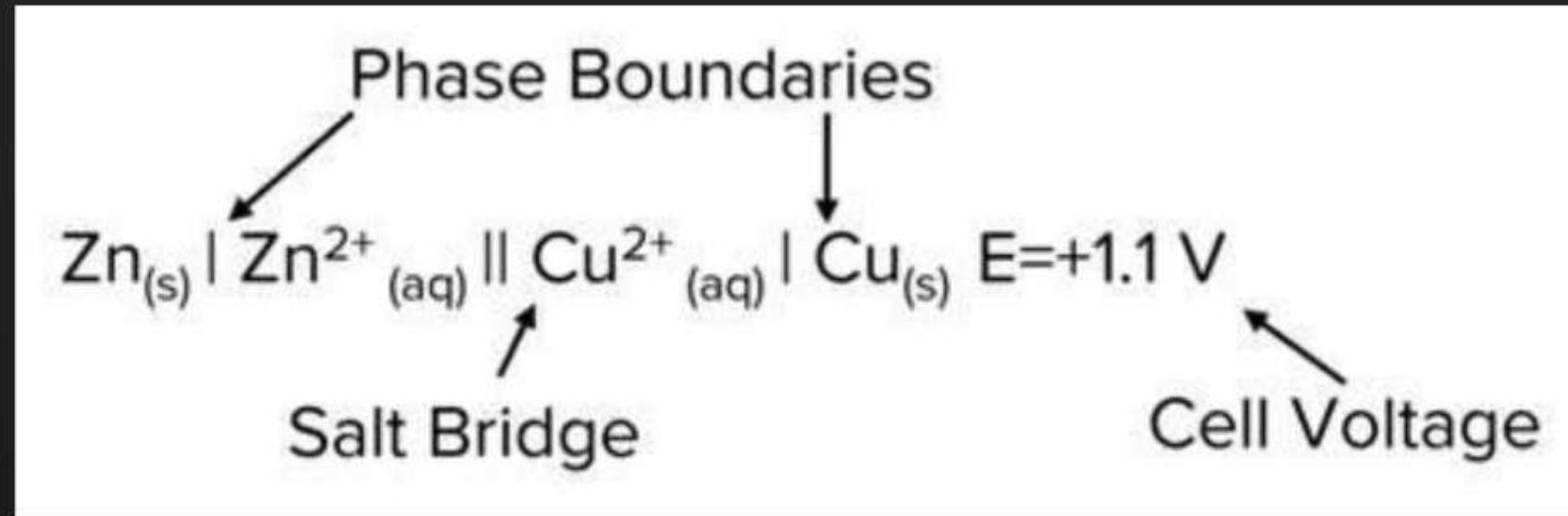

- By convention, the electrode on which oxidation takes place is written on the left hand side.
- The other electrode on which reduction takes place is written on the right hand side.

molar conductance  $\uparrow$  with dilution.



Debye Huckel has given the following equation to co-relate the molar conductance at any concentration and molar conductance at infinite dilution.

$$\Lambda_m^c = \Lambda_m^\infty - A\sqrt{C}$$

Here,

$\Lambda_m^c$  = Molar conductivity at concentration  $c$ .

$\Lambda_m^\infty$  or  $\Lambda_m^c$  = Molar conductivity at infinite dilution

$C$  = Molar concentration of the electrolyte.

$A$  = Constant depending upon the nature of solvent and temperature.

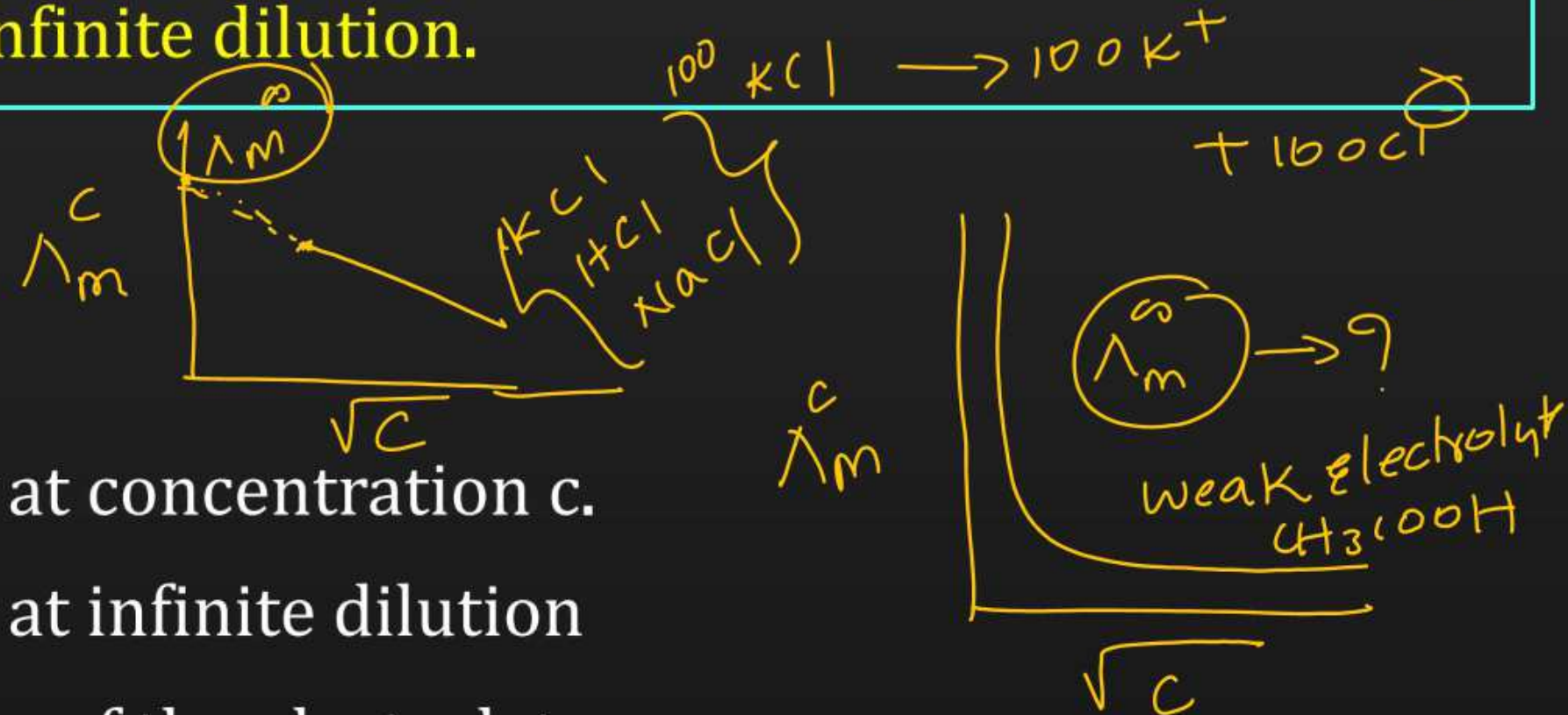

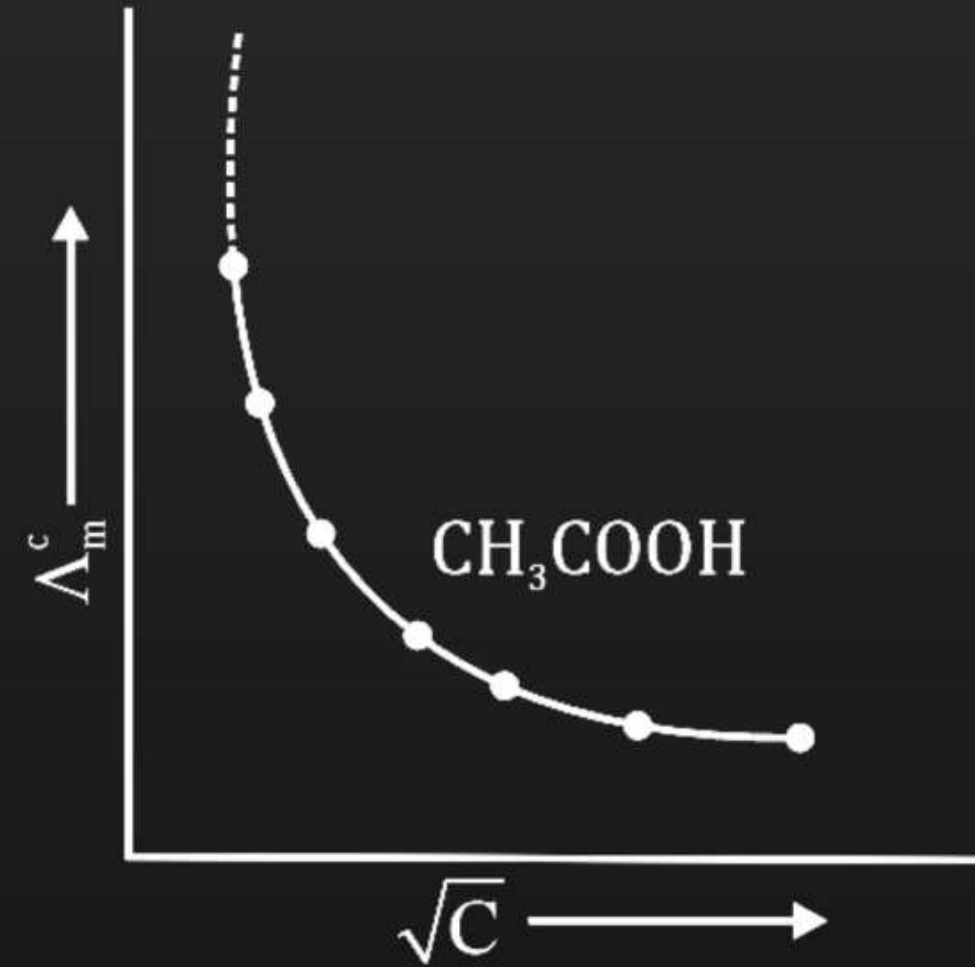
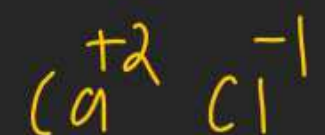
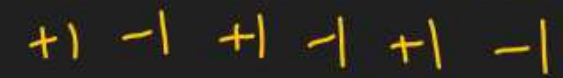
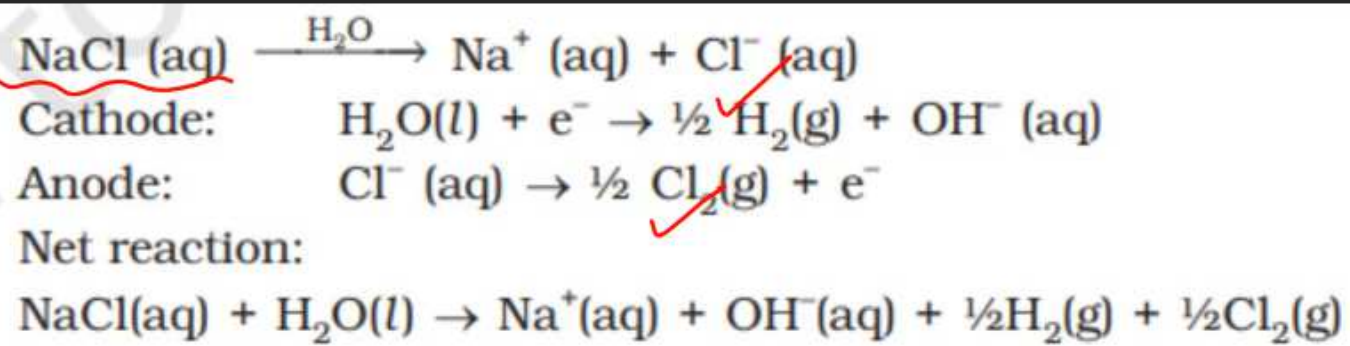

Figure 3.17 variation of  $\Lambda_m^c$  with  $\sqrt{C}$  for weak electrolyte ( $\text{CH}_3\text{COOH}$ )



- For a particular solvent at a given temperature, the value of A depends upon nature of the electrolyte i.e. charges on the cation and anion produced on the dissociation of the electrolyte.
- For example, KCl, CaCl<sub>2</sub> and Na<sub>2</sub>SO<sub>4</sub> are known as 1-1, 2-1 and 1-2 electrolytes respectively.
- All the electrolytes of the same type (e.g. NaCl, KCl, KNO<sub>3</sub>) have the same value of A. These are 1-1 electrolytes.
- A graph between  $\Lambda_m$  and  $\sqrt{C}$  for a strong electrolyte (KCl) has been shown in the Fig. 3.16.
- By extrapolation, the limiting molar conductance ( $\Lambda_m^0$ ) can be obtained.





The standard electrode potentials are replaced by electrode potentials given by Nernst equation (Eq. 2.8) to take into account the concentration effects. During the electrolysis of sulphuric acid, the following processes are possible at the anode:



For dilute sulphuric acid, reaction (2.38) is preferred but at higher concentrations of  $\text{H}_2\text{SO}_4$ , reaction (2.39) is preferred.

*anode  $\rightarrow \text{O}_2$*   
*cathode  $\rightarrow \text{H}_2$*   
*dil.  $\text{H}_2\text{SO}_4$*   
*conc.  $\text{H}_2\text{SO}_4$*   
*cathode  $\rightarrow \text{H}^+$   $\rightarrow \text{H}_2 \uparrow$*

## Question



$\text{Zn} \rightarrow \text{Zn}^{2+} + 2\text{e}^-; E^\circ = +0.76 \text{ V}$ ,  $\text{Fe} \rightarrow \text{Fe}^{2+} + 2\text{e}^-; E^\circ = +0.41 \text{ V}$  The e.m.f. for the cell reaction  $\text{Fe}^{2+} + \text{Zn} \rightarrow \text{Zn}^{2+} + \text{Fe}$  is

**A**  $-0.35 \text{ V}$  ~~X~~

~~**B**  $+0.35 \text{ V}$~~

**C**  $+1.17 \text{ V}$

**D**  $-1.17 \text{ V}$  ~~X~~

$$E_{\text{cell}}^\circ = E_{\text{cathode}}^\circ - E_{\text{anode}}^\circ$$

$$= 0.76 - 0.41$$

$$E_{\text{cell}}^\circ = 0.35 \text{ V}$$

## Question



For a cell the reaction is  $\text{Mg}_{(s)} + \text{Cu}_{(aq)}^{2+} \rightarrow \text{Cu}_{(s)} + \text{Mg}_{(aq)}^{2+}$ . If the standard reduction potentials of Mg and Cu are  $-2.37\text{ V}$  and  $0.34\text{ V}$  respectively, the EMF of the cell is

**A**  $-2.71\text{ V}$

~~**B**  $2.71\text{ V}$~~

**C**  $-2.03\text{ V}$

**D**  $2.03\text{ V}$

anode → cathode

$$E_{\text{cell}} = E^{\circ}_{\text{cathode}} - E^{\circ}_{\text{anode}}$$
$$= 0.34 - (-2.37)$$
$$= 0.34 + 2.37$$

$\frac{1}{2} \text{R.A.}$  →  $e^{\ominus}$  donor

if  $E^{\circ}$  value is  $-ve$  or less positive → anode  
if  $E^{\circ}$  value is  $+ve$  or more +ve → cathode ( $e^{\ominus}$  acceptor)

$\frac{1}{2} \text{R.A.}$

$$\begin{array}{r} 2.37 \\ 0.34 \\ \hline 2.71 \end{array}$$



# Question



For the reaction  $2A_{(s)} + B_{(aq)}^{2+} \rightarrow 2A^+_{(aq)} + B_{(s)}$ , Nernst equation for the EMF of the cell is

**A**  $E = E^\circ - \frac{RT}{2F} \ln \frac{[A^+]^2}{[B^{2+}]}$

**B**  $E = E^\circ + \frac{RT}{2F} \ln \frac{[A^+]^2}{[B^{2+}]}$

**C**  $E = E^\circ - \frac{RT}{F} \ln \frac{[A^+]^2}{\sqrt{[B^{2+}]}}$

**D**  $E = E^\circ + \frac{RT}{F} \ln \frac{[A^+]^2}{[B^{2+}]}$

298K

$R = 8.314$   
 $T = 298K$   
 $F = 96500C$

0.059

$$E = E^\circ_{cell} - \frac{RT}{2F} \log \frac{[A^+]^2}{[B^{2+}]}$$

$$E_{cell} = E^\circ_{cell} + \frac{RT}{2F} \log \frac{[B^{2+}]}{[A^+]^2}$$

# Question



Which reaction is not feasible?

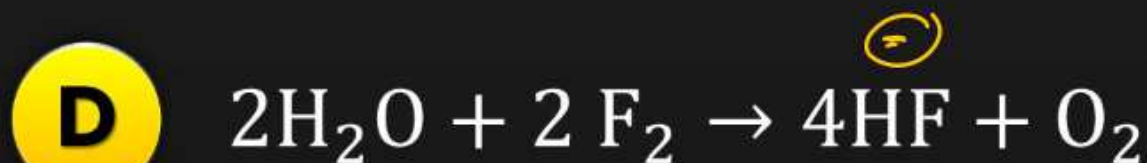
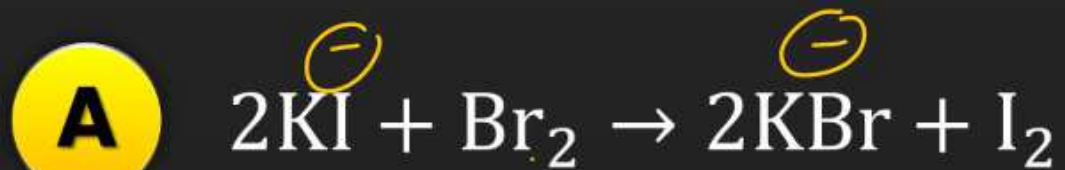

not feasible

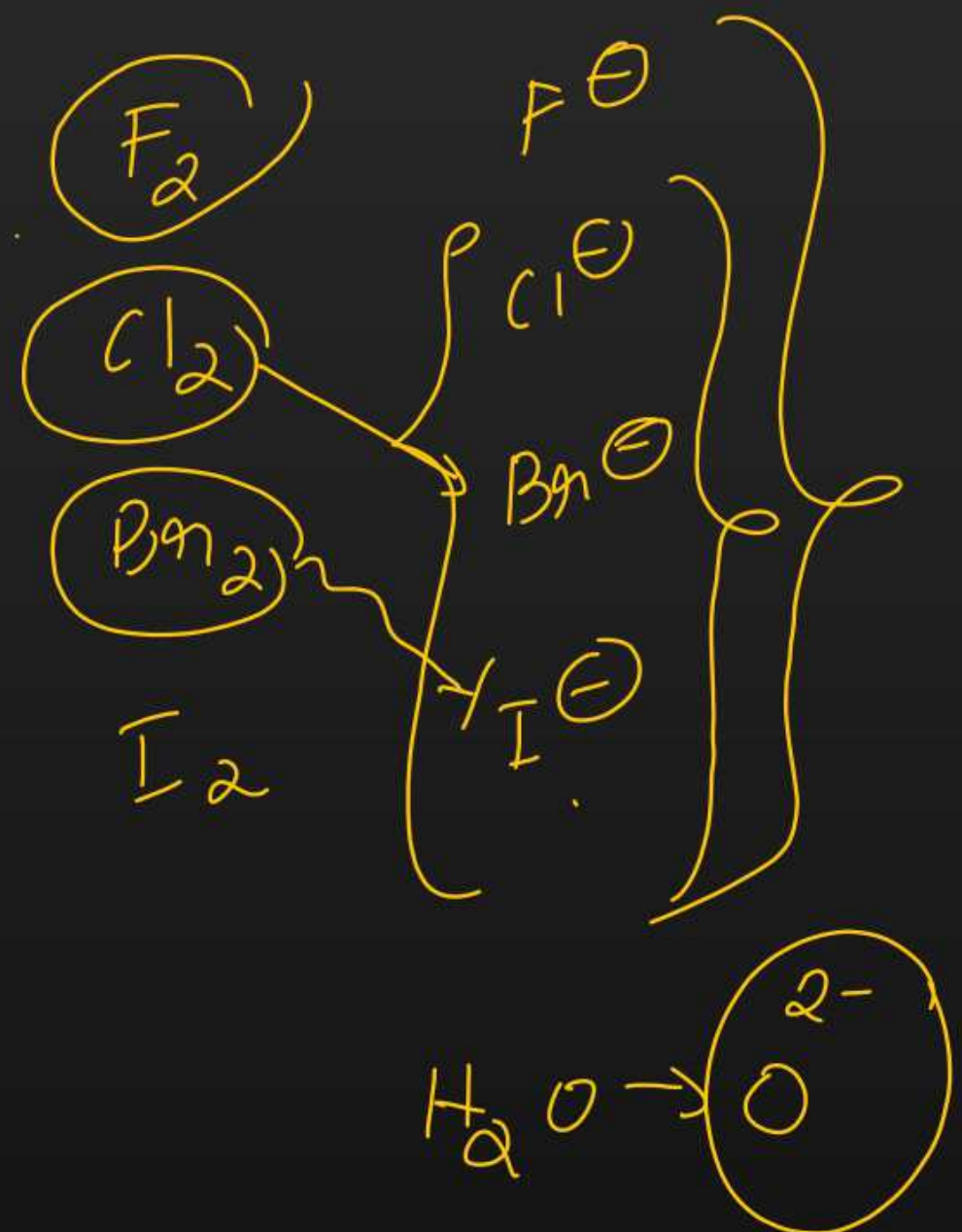

# Question



The value of  $\Delta G(\text{kJ mol}^{-1})$  for the cell having  $E^\circ_{\text{Cu}} = 0.059$  is  
(take  $1F = 96500 \text{ C mol}^{-1}$ )

- A** -5.7
- B** 5.7
- C** 11.4
- D** -11.4

$$\Delta G^\circ = -nFE^\circ$$

$$\Delta G^\circ = -2 \times 0.059 \times 96,500$$

$$\Delta G^\circ = -\left(2 \times 0.06 \times 96,500\right)$$

$$= -2 \times \frac{6 \times 96,500}{100}$$

$$\Delta G^\circ = \frac{-1,1400 \text{ J}}{1000} = -11.4$$

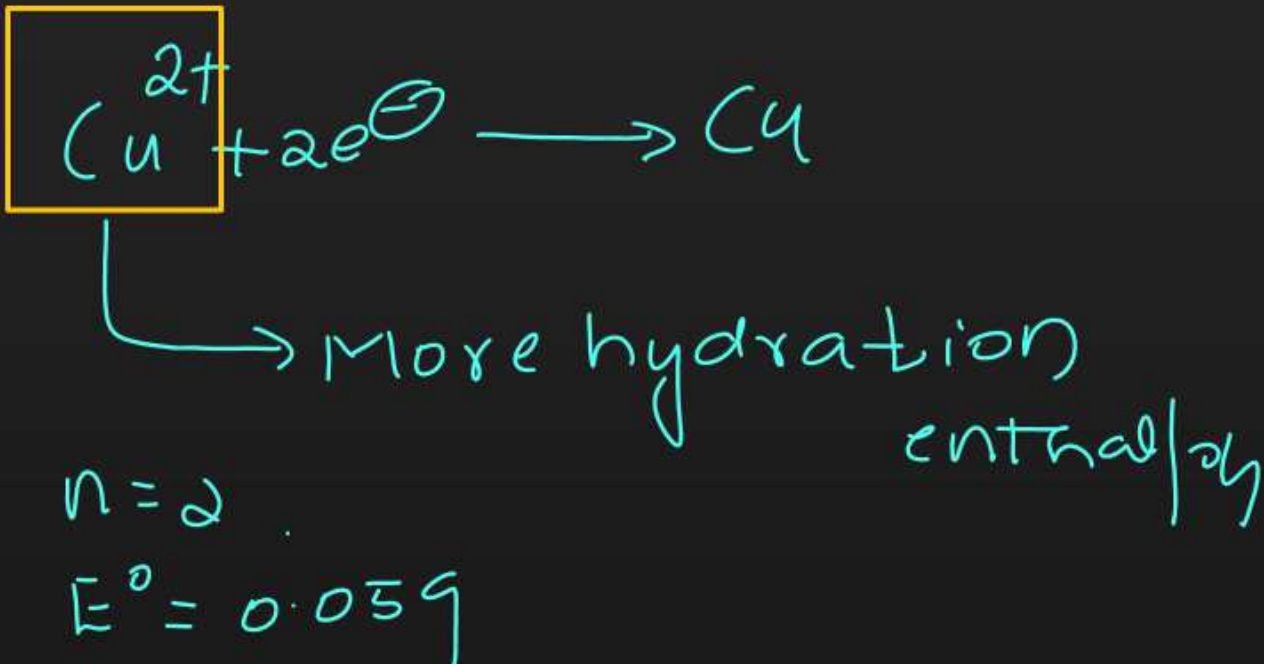

# Question



The equilibrium constant (K) for the reaction  $\text{Cu}_{(s)} + 2\text{Ag}_{(aq)}^{\circ} \rightarrow \text{Cu}_{(aq)}^{2+} + 2\text{Ag}_{(s)}$  will be [Given  $E_{\text{cell}}^{\circ} = 0.46$ ]

**A**  $K_C = \text{Antilog } 15.6$

**B**  $K_C = \text{Antilog } 2.5$

**C**  $K_C = \text{Antilog } 1.5$

**D**  $K_C = \text{Antilog } 12.2$

$$E_{\text{cell}}^{\circ} = 0.46 \text{ V}$$

$$n = 2$$

$$E_{\text{cell}}^{\circ} = \frac{0.0591}{n} \log K_C$$

$$15.3 = \log K_C$$

$$K_C = \text{Antilog } (15.3)$$

$$0.46 = \frac{0.0591}{2} \log K_C$$

$$\frac{0.46 \times 2}{0.0591} = \log K_C$$

$$\frac{0.92}{0.0591} = \log K_C$$

$$15.4 = \log K_C$$

$$\frac{15.3}{0.0591} = 20$$

## Question



Specific conductance of 0.1 M nitric acid is  $6.3 \times 10^{-2} \text{ ohm}^{-1} \text{ cm}^{-1}$ . The molar conductance of the solution is

- A**  $630 \text{ ohm}^{-1} \text{ cm}^2 \text{ mol}^{-1}$
- B**  $315 \text{ ohm}^{-1} \text{ cm}^2 \text{ mol}^{-1}$
- C**  $6.300 \text{ ohm}^{-1} \text{ cm}^2 \text{ mol}^{-1}$
- D**  $63.0 \text{ ohm}^{-1} \text{ cm}^2 \text{ mol}^{-1}$

$$\Lambda_m = \frac{1000 \times K}{C}$$

$$\Lambda_m = \frac{1000 \times 6.3 \times 10^{-2}}{0.1}$$

$$= 1000 \times 6.3 \times 10^{-2} \times 10$$

$$= 6.3 \times 10^{-2} \times 10^4$$

$$= 6.3 \times 10^2 = 630 \text{ S cm}^2 \text{ mol}^{-1}$$
$$= 630 \text{ ohm}^{-1} \text{ cm}^2 \text{ mol}^{-1}$$

$$\frac{63 \times 10^2}{10}$$

## Question

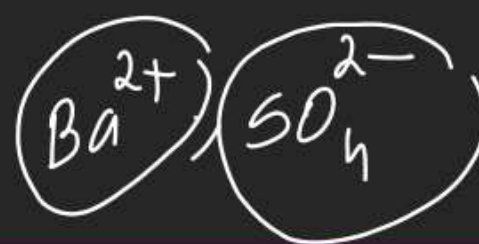

Molar ionic conductivities of a bivalent electrolyte are 57 and 73. The molar conductivity of the solution will be

**A**  $130 \text{ S cm}^2 \text{ mol}^{-1}$

**B**  $65 \text{ S cm}^2 \text{ mol}^{-1}$

**C**  $260 \text{ S cm}^2 \text{ mol}^{-1}$

**D**  $187 \text{ S cm}^2 \text{ mol}^{-1}$

$$\Lambda_m^0 = x \lambda_{2+}^0 + y \lambda_{2-}^0$$

$$\Lambda_m^0 = 57 + 73 = 130 \text{ S cm}^2 \text{ mol}^{-1}$$

## Question



How many coulombs are required for the reduction of 1 mol of  $\text{Cu}^{2+}$  to Cu ?

**A**  $1.23 \times 10^5 \text{C}$  ✗

**B**  $1.63 \times 10^5 \text{C}$  }

**C**  $1.93 \times 10^5 \text{C}$  ✓

**D**  $2.12 \times 10^5 \text{C}$  ✗

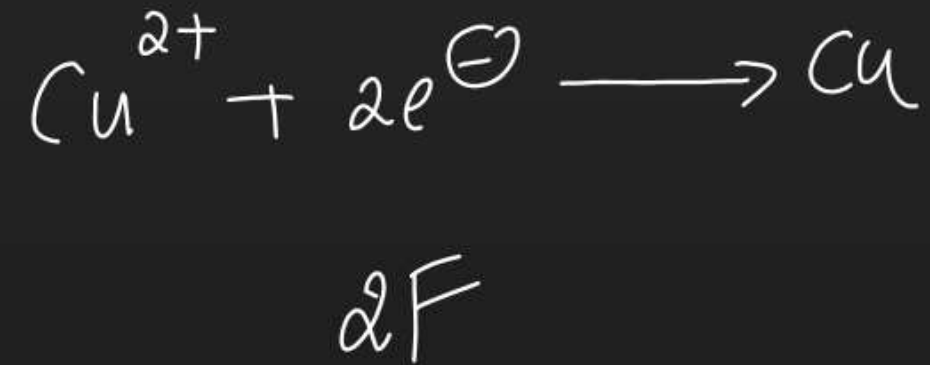

# Question



At STP 1.12 litre of H<sub>2</sub> is obtained on flowing a current for 965 seconds in a solution. The value of current is

- A 10
- B 1.0
- C 1.5
- D 2.0

Molar volume  $\rightarrow$  1 mole = 22.4 L

22.4 L  $\rightarrow$  2 g (H<sub>2</sub>)

1.12 L  $\rightarrow$  ?

$\frac{1.12 \times 2}{22.4} = 0.1 \text{ g}$

$W = Z \times I \times t$

$0.1 = \frac{\text{Eq wt of H}}{96500} \times I \times 965$

$0.1 = \frac{1}{96500} \times I \times 965$

$0.1 = I$

$I = 10 \text{ A}$

$\text{H}^{\oplus} + \text{e}^{\ominus} \rightarrow \text{H}$

$\text{H} = \frac{1}{1} = 1 \text{ g eq. wt}$

# Question



At STP 1.12 litre of H<sub>2</sub> is obtained on flowing a current for 965 seconds in a solution. The value of current is

- ~~A~~ 10
- B 1.0
- C 1.5
- D 2.0

Molar volume  $\rightarrow$  1 mole = 22.4 L

22.4 L  $\rightarrow$  2 g (H<sub>2</sub>)  
 1.12 L  $\rightarrow$  ?

~~$\frac{1.12 \times 2}{22.4}$~~  = 0.1 g

$$W = Z \times I \times t$$

$0.1 = \frac{\text{Eq. wt of H}}{96,500} \times I \times 965$

$0.1 = \frac{1}{96,500} \times I \times 965$

$0.1 = I$

$\xrightarrow{100}$

$$I = 10 \text{ A}$$

Eq. wt of Hydrogen

$$\frac{1}{1} = \frac{1}{1}$$

$$= 1 \text{ g eq}^{-1}$$

# Question

$$[H^+] = c\alpha$$

$$= 0.1 \times 0.01$$

$$[H^+] = 10^{-3} = 0.001 \text{ mol dm}^{-3}$$

$$pH = -\log[H^+] = -\log 10^{-3}$$



The resistance of 0.1 M weak acid HA in a conductivity cell is  $2 \times 10^3$  Ohm. The cell constant of the cell is  $0.78 \text{ cm}^{-1}$  and  $\Lambda_m^\infty$  of acid HA is  $390 \text{ S cm}^2 \text{ mol}^{-1}$ . The pH of the solution is

**A** 3.3

$$R = 2 \times 10^3 \text{ ohm}$$

$$\frac{l}{a} = 0.78 \text{ cm}^{-1}$$

$$K = \frac{1}{R} \times \frac{l}{a}$$

$$= \frac{1}{2 \times 10^3} \times 0.78$$

$$pH = -\log[H^+]$$

$$[H^+] = c\alpha$$

**B** 4.2

$$\Lambda_m^\infty = 390 \text{ S cm}^2 \text{ mol}^{-1}$$

$$\alpha = \frac{\Lambda_m^c}{\Lambda_m^\infty}$$

**C** 5

$$pH = 9$$

$$K = 0.39 \times 10^{-3} \text{ S cm}^{-1}$$

$$\Lambda_m^c = \frac{1000 \times K}{c}$$

$$c = 0.1$$

$$\Lambda_m = 3.9 \text{ S cm}^2 \text{ mol}^{-1}$$

$$K = \frac{1}{R} \times \frac{l}{a}$$

**D** 3

$$\Lambda_m^c = \frac{1000 \times K}{c}$$

$$\alpha = \frac{\Lambda_m^c}{\Lambda_m^\infty}$$

$$= \frac{1000 \times 0.39 \times 10^{-3}}{0.1} = \frac{39 \times 10}{100} = 3.9$$

$$= \frac{3.9}{390} = \frac{39}{10 \times 39 \times 10} \times \frac{0.01}{10}$$



$$[H^+] = 10^{-5}$$

$$pH = 5$$

$$[H^+] = 10^{-6}$$

$$pH = 6$$



Acid  $\rightarrow H^+$   
 $C \times \alpha \rightarrow$  No. of ions.

$$\log a^b = b \log a$$

$$H_2SO_4 \rightarrow 2H^+ + SO_4^{2-} \quad \log 10^{-3} = -(-3 \log_{10} 10)$$
  
 $C 10^3 = 2 \times 10^3$

$$\log_{10} 10 = 1$$

$$= 3$$

$$[H^+] = 10^{-pH}$$

$$pH = -\log [H^+]$$
  
$$pH = -\log [2 \times 10^{-3}]$$

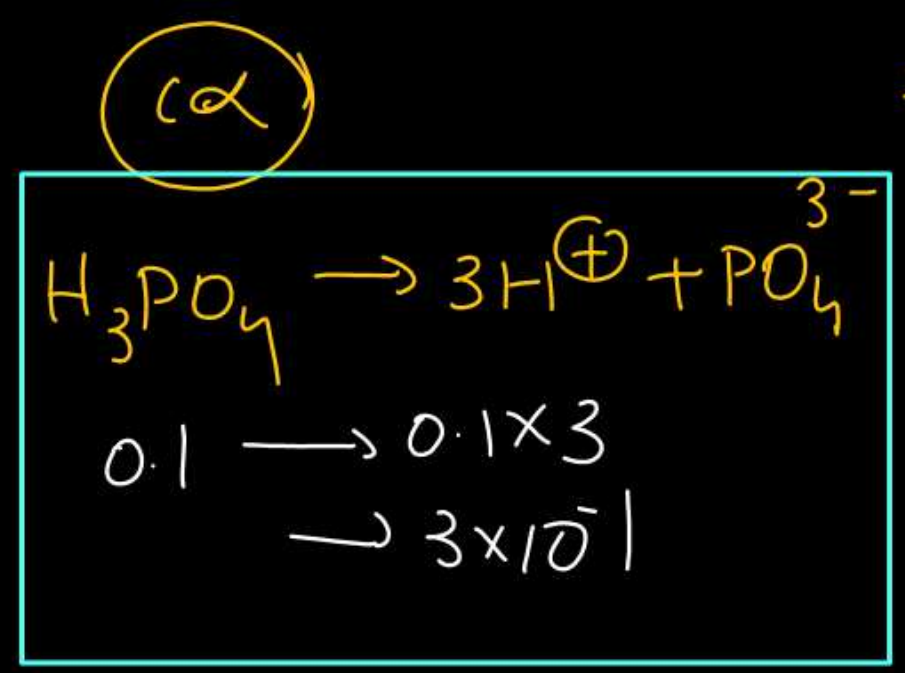

## Question

Consider the following 4 electrodes

A :  $\text{Ag}^+$   $10^{-4}$  (0.0001 M)/Ag(s) ;

B :  $\text{Ag}^+$   $10^{-1}$  (0.1 M)/Ag(s) ;

C :  $\text{Ag}^+$   $10^{-2}$  (0.01 M)/Ag(s) ;

D :  $\text{Ag}^+$   $10^{-3}$  (0.001 M)/Ag(s) ;  $E^\circ_{\text{Ag}^+/\text{Ag}} = +0.80 \text{ V}$

Then reduction  $E_{\text{cell}}$  potential in volts of the electrodes in the order.

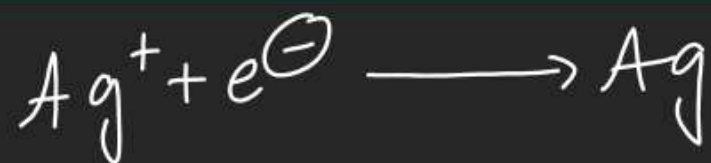

$$E_{\text{cell}} = E_{\text{cell}}^\circ - \frac{0.059}{n} \log \frac{[\text{Ag}]}{[\text{Ag}^+]}$$

$$E_{\text{cell}} = E_{\text{cell}}^\circ + \frac{0.059}{1} \log [\text{Ag}^+]$$

~~A~~ B > C > D > A

~~B~~ ~~C~~ > ~~D~~ > A > B

~~C~~ A > D > ~~C~~ > B

~~D~~ ~~A~~ > ~~B~~ > C > D

## Question



Consider the following electrodes

$P = \text{Zn}^{2+} (0.0001 \text{ M})/\text{Zn}$ ,  $Q = \text{Zn}^{2+} (0.1 \text{ M})/\text{Zn}$

$R = \text{Zn}^{2+} (0.01 \text{ M})/\text{Zn}$ ,  $S = \text{Zn}^{2+} (0.001 \text{ M})/\text{Zn}$

$E^\circ(\text{Zn}/\text{Zn}^{2+}) = -0.76 \text{ V}$  electrode potentials of the above electrodes in volts are in the order

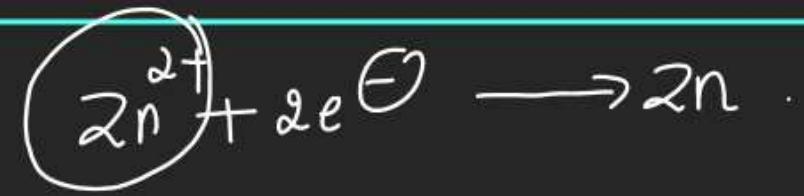

**A**  $P > S > R > Q$

**B**  $S > R > Q > P$

**C**  $Q > R > S > P$

**D**  $P > Q > R > S$

**Thank**

**You**