



CBSE Board Paper Solution-2020

Class	: X
Subject	: Science
Set	: 1
Code No	: 31/4/1
Time Allowed	: 3 Hours
Maximum Marks	: 80

General Instructions:

Read the following instructions very carefully and strictly follow them :

- (i) This question paper comprises **three** sections–A, B, and C. There are **30** questions in the question paper. All questions are compulsory.
- (ii) **Section A** : Question no. **1** to **14** all questions or part thereof are of **one** mark each. These questions comprise Multiple Choice Questions (MCQ), Very Short Answer (VSA) and Assertion-Reason type questions. Answer to these questions should be given in **one word** or **one sentence**.

- (iii) **Section B** : Question no. **15** to **24** are short answer type questions, carrying **3** marks each. Answer to these questions should not exceed **50** to **60** words.
- (iv) **Section C** : Question no. **25** to **30** are long answer type questions, carrying **5** marks each. Answer to these questions should not exceed **80** to **90** words.
- (v) Answers should be brief and to the point. Also the above mentioned word limit be adhered to as far as possible.
- (vi) There is no overall choice in the question paper. However, an internal choice has been provided in some questions in each section. **Only one of the choices** in such questions have to be attempted.
- (vii) In addition to this, separate instructions are given with each section and question, wherever necessary.

SECTION-A

1. Write the number of valence electrons present in a nitrogen atom $\left(\begin{matrix} 14 \\ 7 \end{matrix} \text{N} \right)$. [1]

Answer: Five

2. Define the term induced electric current. [1]

Answer: The electric current induced in a conductor due to the change in magnetic field is known as induced current.

3. Answer question number 3(a) – 3(d) on the basis of your understanding of the following paragraph and the related studied concepts.

Around the year 1800, only 30 elements were known. Dobereiner in 1817 and Newlands in 1866 tried to arrange the then known elements and framed laws which were rejected by the scientists. Even after the rejection of the proposed laws, many scientists continued to search for a pattern that correlated the properties of elements with their atomic masses.

The main credit for classifying elements goes to Mendeleev for his most important contribution to the early development of a Periodic table of element wherein the arranged the elements on the basis of their fundamental property, the atomic mass and also on the similarity of chemical properties. The formulae of their

hydrides and oxides were treated as basic criteria for the classification of the elements.

However, Mendeleev's classification also had some limitations as it could not assign the position to isotopes. He also left some gaps in the periodic table.

3(a) State Mendeleev's Periodic Law. [1]

3(b) Why did Mendeleev leave some gaps in the Periodic table? [1]

3(c) If the letter 'R' was used to represent any of the elements in the group, then the hydride and oxide of carbon would respectively be represented as

(i) RH_4 , RO

(ii) RH_4 , RO_2

(iii) RH_2 , RO_2

(iv) RH_2 , RO

[1]

3 (d) Isotopes are

(i) Atoms of an element with similar chemical properties but different atomic masses.

(ii) Atoms of different elements with similar chemical properties but different atomic masses.

(iii) Atoms of an element with different chemical properties but same atomic masses.

(iv) Atoms of different elements with different chemical properties but same atomic masses.

[1]

Answer:

(a) According to the Mendeleev's periodic law, the physical and chemical properties of elements are periodic function of their atomic masses.

(b) Mendeleev predicted the existence and the properties of some elements, which were not known at that time. Therefore, he left some gaps in the Periodic table.

(c) (ii)

(d) (i)

4. Answer question numbers 4 (a) - 4 (d) on the basis of your understanding of the following paragraph and the related studies concepts-

India today is facing the problem of overuse of resources, contamination of water and soil and lack of methods of processing the waste. The time has come for the world to say goodbye to "single-use plastics". Steps must be undertaken to develop environment- friendly substitutes, effective plastic waste collection and methods of its disposal.

Indore treated 15 lakh metric tonnes of waste in just 3 years, through biomining and bioremediation techniques. Bioremediation

involves introducing microbes into a landfill to naturally 'break' it down and biomining involves using trammel machines to sift through the waste to separate the 'soil' and the waste component. The city managed to chip away 15 lakh metric tonnes of waste at a cost of around Rs 10 crore. A similar experiment was successfully carried out in Ahmedabad also.

4(a) State two methods of effective plastic waste collection in your school. [1]

4(b) Name any two uses of "single use plastic" in daily life. [1]

4(c) If we discontinue the use of plastic, how can an environment-friendly substitute be provided? [1]

4(d) Do you think microbes will work similarly in landfill sites as they work in the laboratory? Justify your answer. [1]

Answer: (a) Two methods of effective plastic waste collection in the school are-

- i. Curbside Recycling
- ii. Drop-Off Recycling

(b) Two uses of "single use plastic" in daily life are-

- i. Plastic grocery bags
- ii. Plastic drinking bottles

(c) If we discontinue the use of plastic, we can use long-lasting environment-friendly substitutes like stainless steel or glass water bottles, reusable shopping bags, eco-friendly cutlery etc.

(d) Yes, microbes can work in landfill sites as they work in laboratory. The landfills can be broken down naturally by the process of bioremediation that involves the microbes.

5. Which of the following statement is correct about the human circulatory system?

- (A) Blood transports only oxygen and not carbon dioxide.**
- (B) Human heart has five chambers.**
- (C) Valves ensure that the blood does not flow backwards.**
- (D) Both oxygen-rich and oxygen-deficient blood gets mixed in the heart.**

[1]

Answer: (C)

Explanation: Blood can flow from the atria down into the ventricles. Valves open in one direction like trapdoors to let the blood pass through. Then they close, so the blood cannot flow backwards into the atria.

6. Anaerobic process

- (A) takes place in yeast during fermentation.**
- (B) takes place in the presence of oxygen.**
- (C) produces only energy in the muscles of human beings.**

(D) Produces ethanol, oxygen and energy.

[1]

Answer: (A)

Explanation: In yeast, anaerobic fermentation takes place in the presence of sugar but absence of oxygen. Anaerobic fermentation in yeast results in the production of ethanol and carbon dioxide.

OR

Most of the digestion and absorption of the food takes place in the

- (A) small intestine.**
- (B) liver.**
- (C) stomach.**
- (D) large intestine.**

[1]

Answer: (A)

Explanation: The small intestine is the part of digestive system where much of the digestion and absorption of food takes place. The primary function of the small intestine is to absorb nutrients and minerals present in the food.

7. Fertilisation is the process of

- (A) transfer of male gamete to female gamete.**
- (B) fusion of nuclei of male and female gamete.**
- (C) adhesion of male and female reproductive organs.**
- (D) the formation of gametes by a reproductive organ.**

[1]

Answer: (B)

Explanation: Fertilisation is the process of fusion of haploid gametes, (male and female) to form the diploid zygote.

8. If a person has five resistors each of value $\frac{1}{5} \Omega$, then the maximum resistance he can obtain by connecting them is [1]

(A) 1Ω

(B) 5Ω

(C) 10Ω

(D) 25Ω

Answer: (A)

Series combination of resistors gives maximum resistance

$$R_{\text{equivalent}} = R_1 + R_2 + R_3 + R_4 + R_5$$

$$R_{\text{equivalent}} = \frac{1}{5 \Omega} + \frac{1}{5 \Omega} + \frac{1}{5 \Omega} + \frac{1}{5 \Omega} + \frac{1}{5 \Omega} = 1 \Omega$$

OR

The resistance of a resistor is reduced to half of its initial value. In doing so, if other parameters of the circuit remain unchanged, the heating effects in the resistor will become

[1]

(A) two times.

- (B) half.**
- (C) one-fourth.**
- (D) four times.**

Answer: (B)

Joule's law of heating is given by $H = I^2RT$

If other parameters remain constant, the amount of heat produced, H is directly proportional to R.

9. Fleming Right-hand rule gives [1]

- (A) magnitude of the induced current.**
- (B) magnitude of the magnetic field.**
- (C) direction of the induced current.**
- (D) both, direction and magnitude of the induced current.**

Answer: (C)

Fleming's right-hand rule states that if we stretched our right hand's thumb, index finger and middle finger in such a way so that all three are mutually perpendicular, thumb shows the direction of motion of conductor with respect to magnetic field, index finger shows the direction of magnetic field than middle finger shows the direction of induced current in the conductor.

10. Which one of the following statements is not true about nuclear energy generation in a nuclear reactor? [1]

- (A) Energy is obtained by a process called nuclear fission.**

- (B) The nucleus of Uranium is bombarded with high energy neutrons.**
- (C) A chain reaction is set in the process.**
- (D) In this process a tremendous amount of energy is released at a controlled rate.**

Answer: (B)

Slow moving neutrons are bombarded on the nucleus of Uranium to break the nucleus in smaller stable nuclei.

OR

The biggest source of energy on Earth's surface is [1]

- (A) Biomass**
- (B) Solar radiations**
- (C) Tides**
- (D) Winds**

Answer: (B)

Maximum energy present on the earth is converted form of solar energy.

11. Food web is constituted by [1]

- (A) relationship between the organism and the environment.**
- (B) relationship between plants and animals.**
- (C) various interlinked food chains in an ecosystem.**

(D) relationship between animals and environment.

Answer: (C)

In a food web, many food chains are linked together. Thus, it is a network of interlinked food chains in an ecosystem. In this network, every organism is eaten by more than one organism, who are again eaten by other different organisms. Unlike a food chain, the food web is represented by the crisscross pattern of lines.

12. Choose the incorrect statement from the following:

[1]

(A) Ozone is a molecule formed by three atoms of oxygen.

(B) Ozone shields the surface of the Earth from ultraviolet radiations.

(C) Ozone is deadly poisonous.

(D) Ozone gets decomposed by UV radiations.

Answer: (D)

Ozone (O_3) is an inorganic molecule made up of three oxygen atoms. It is not decomposed by UV (ultraviolet) radiations, rather these radiations help in the formation of ozone.

The chemical reaction involved in ozone formation is as follows:

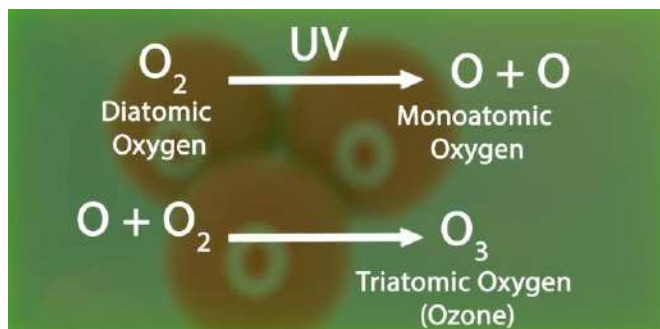

13. For question numbers 13 and 14, two statements are given- one labelled as Assertion (A) and the other labelled as Reason (R). Select the correct answer to these questions from the codes (a), (b), (c) and (d) as given below:

- (a) Both (A) and (R) are true and (R) is the correct explanation of the assertion (A).
- (b) Both (A) and (R) are true, but (R) is not the correct explanation of the assertion (A).
- (c) (A) is true, but (R) is false.
- (d) (A) is false, but (R) is true.

Assertion (A): Following is a balanced chemical equation for the action of steam on iron:

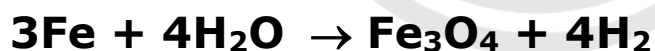

Reason (R): The law of conservation of mass holds good for a chemical equation.

[1]

Answer: (a)

14. Assertion (A): The sex of a child in human beings will be determined by the type of chromosome he/she inherits from the father.

Reason (R): A child who inherits 'X' chromosome from his father would be a girl (XX), while a child who inherits a 'Y' chromosome from the father would be a boy (XY). [1]

Answer: (a) Both (A) and (R) are true and ® is the correct explanation of the assertion (A).

All human beings have 23 pairs of chromosomes in the nuclei of their cells. Out of these two are the sex chromosomes named as X and Y.

A female has two X chromosomes while male has one X and one Y chromosome.

If the sperm containing X chromosome fertilize the egg. The zygote will contain two X sex chromosomes. This zygote will develop into a female child.

If the sperm has Y chromosome and it fertilizes the egg the zygote. The zygote will develop into the male child.

Hence, the type of sperm contributed by father determines the sex of the unborn baby.

SECTION-B

15. Lead nitrate solution is added to a test tube containing potassium iodide solution.

(a) Write the name and colour of the compound precipitated.

(b) Write the balanced chemical equation for the reaction involved.

(c) Name the type of this reaction justifying your answer.

[3]

Answer:

(a) Name of compound precipitated: Lead iodide

Colour of the compound precipitated: Yellow

(b) $2\text{KI}(\text{s}) + \text{Pb}(\text{NO}_3)_2(\text{aq}) \longrightarrow 2\text{KNO}_3(\text{aq}) + \text{PbI}_2(\text{s})$

(c) This is a double displacement reaction because in the reaction two compounds exchange their ions to form two new compounds. Here both lead nitrate and potassium iodide are exchanging their ions.

OR

What happens when food materials containing fats and oils are left for a long time/ List two observable changes and suggest three ways by which this phenomenon can be prevented. [3]

Answer: When food materials containing fats and oils are left for a long time they undergo oxidation and their **taste** and **smell change**.

This can be prevented by–

1. Using airtight and light protecting packing
2. Using antioxidants like vitamin A and C
3. Filling nitrogen gas in chips container

16. List three differentiating features between the processes of galvanisation and alloying. [3]

Answer:

Galvanisation	Alloying
Galvanisation is the process of depositing a thin layer of zinc metal on iron objects to protect them for rusting.	A homogeneous mixture of two or more metals or a metal and a non-metal to change the properties of pure state metals and protect them from rust.
It can be done by spraying molten zinc on the iron surface and dipping iron objects into molten zinc.	It can be done by alloying iron object with the chromium and nickel.
It does not affect the properties of iron (metal).	It changes the hardness, tensile strength and electrical resistance of a metal.

OR

Compare in tabular form the reactivities of the following metals with cold and hot water:

(a) Sodium

(b) Calcium

(c) Magnesium

[3]

Answer:

Metal	Reactivity	Reactions
Sodium (Na)	It reacts vigorously	$2\text{Na(s)} + 2\text{H}_2\text{O(l)} \longrightarrow 2\text{NaOH(aq)} + \text{H}_2\text{(g)}$

	with cold water.	
Calcium (Ca)	It reacts slowly with cold water and moderately with hot water.	$\text{Ca(s)} + 2\text{H}_2\text{O(l)} \longrightarrow \text{Ca(OH)}_2 + \text{H}_2\text{(g)}$ (Hot)
Magnesium (Mg)	Magnesium does not react with cold water. It reacts slowly with hot water and vigorously with steam.	$\text{Mg(s)} + 2\text{H}_2\text{O(l)} \longrightarrow \text{Mg(OH)}_2 + \text{H}_2\text{(g)}$ (Hot) $\text{Mg(s)} + \text{H}_2\text{O(l)} \longrightarrow \text{MgO} + \text{H}_2\text{(g)}$ (Steam)

17. Carbon, a member of group 14, forms a large number of carbon compounds estimated to be about three million. Why is this property not exhibited by other elements of this group? Explain. [3]

Answer:

- Tetravalency:** Carbon can easily form four covalent bonds to other atoms.
- Catenation:** Carbon can easily form covalent bonds to other carbon atoms and the carbon-carbon bonds are more stable than the other

element to same element bonds formed by other member of group 14.

- 3. Formation of multiple bonds:** Carbon can form not only a single bond but also it can form double or single bonds with same or different elements.

Since these properties are not exhibited by other elements of this group, therefore, the number of carbon compounds is very large as compared to the other elements of group 14.

- 18. A cheetah, on seeing a prey, moves towards him at a very high speed. What causes the movement of his muscles? How does the chemistry of cellular components of muscles change during this event? [3]**

Answer: A cheetah possesses an extremely flexible spine which allows for extreme flexion and extension while moving towards a prey at a very high speed.

Rapid respiration is required for a high-intensity output of the chasing activity. Thus, a cheetah consequently respire anaerobically. During anaerobic respiration, partial breakdown of glucose takes place, which leads to the accumulation of lactic acid in the muscles as the end-product.

- 19. Define geotropism. Draw a labelled diagram of a plant showing geotropic movement of its parts. [3]**

Answer: Geotropism: Geotropism refers to the growth of the parts of a plant in response to gravity.

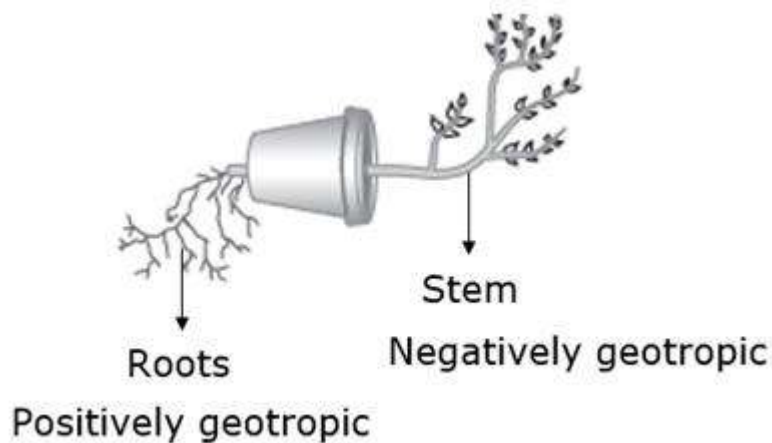

Figure: A plant showing geotropic movement

20. Define the term evolution. "Evolution cannot be equated with progress." Justify this statement.

[3]

Answer: Evolution is the gradual and continuous changes in the traits of an individual that accumulates and enables it to survive better in its surroundings.

Evolution cannot be equated with progress from lower organisms to higher organisms. Evolution leads to the production of diversity and the shaping this diversity by environmental selection. In addition, even the simpler life forms continue to flourish as we can see in case of bacteria. These are one of the simplest life form that inhabit in extreme cold or hot conditions.

OR

"During the course of evolution, organs or features may be adapted for new functions."

Explain this fact by choosing an appropriate example. [3]

Answer: The organs or features adapted for new functions during evolution are:

- (i) Some dinosaur had feathers for insulation in cold weather but in case of birds they were used for flying.
- (ii) Older life forms, such as bacteria were able to survive in most of the inhospitable habitats like, hot springs, deep-sea, thermal vents and the ice in Antarctica.

21. A concave mirror is use for image formation for different positions of an object. What inferences can be drawn about the following when an object is placed at a distance of 10 cm from the pole of a concave mirror of focal length 15 cm?

(A) Position of the image

(B) Size of the image

(C) Nature of the image

Draw a labelled ray diagram to justify your inferences. [3]

Answer: Given,

Position of object, $u = -10$ cm

Focal length of concave mirror, $f = -15$ cm

(a) Using mirror formula,

$$\frac{1}{v} = \frac{1}{f} - \frac{1}{u}$$
$$\Rightarrow \frac{1}{v} = \frac{1}{-15 \text{ cm}} - \frac{1}{(-10 \text{ cm})} = \frac{1}{30 \text{ cm}}$$
$$\Rightarrow v = 30 \text{ cm}$$

So, the position of image is 30 cm behind the mirror.

(b) Using magnification formula, $m = \frac{h_i}{h_o} = -\frac{v}{u}$

$$\Rightarrow \frac{h_i}{h_o} = -\frac{30 \text{ cm}}{(-10 \text{ cm})} = 3 \text{ cm}$$
$$\Rightarrow h_i = 3h_o$$

So, the size of the image is three times that of the size of the object.

Here the object is placed in between focus and pole of the concave mirror, so the image formed will be virtual and magnified.

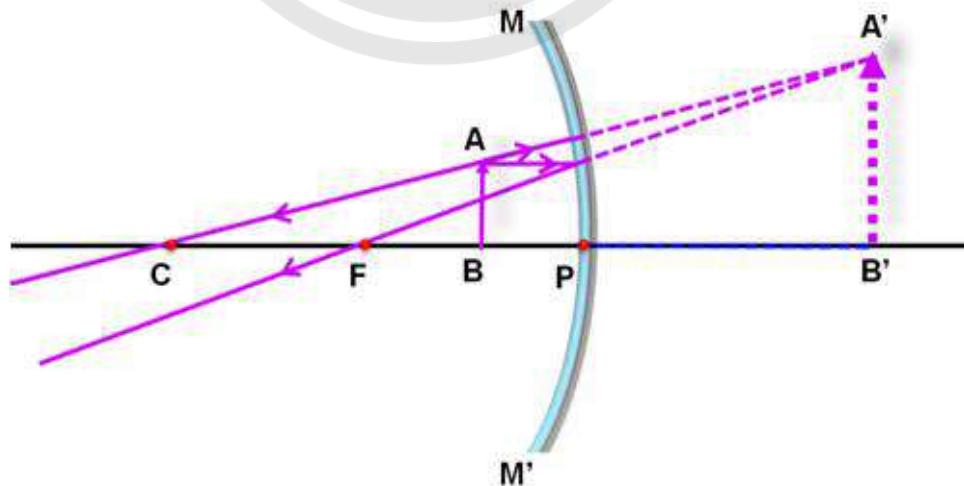

22. The refractive index of a medium 'x' with respect to a medium 'y' is $\frac{2}{3}$ and the refractive index of medium 'y' with respect to medium 'z' is $\frac{4}{3}$. Find the refractive index of medium 'z' with respect to medium 'x'. If the speed of light in medium 'x' is $3 \times 10^8 \text{ ms}^{-1}$, calculate the speed of light in medium 'y' [3]

Answer:

Given :

Refractive index of medium 'x'

with respect to medium 'y', $\mu_{xy} = \frac{2}{3}$

Refractive index of medium 'y'

with respect to medium 'z', $\mu_{yz} = \frac{4}{3}$

Refractive index of medium 'z'

with respect to medium 'x',

$$\mu_{zx} = \frac{1}{\mu_{xy} \times \mu_{yz}} = \frac{1}{\frac{2}{3} \times \frac{4}{3}} = \frac{9}{8}$$

Refractive index of medium 'z'

with respect to medium 'x' is $\frac{9}{8}$.

Speed of light in medium 'y',

$$v = c \times \mu_{xy} = 3 \times 10^8 \text{ m/s} \times \frac{2}{3} = 2 \times 10^8 \text{ m/s}$$

23. A person may suffer from both myopia and hypermetropia defects.

(a) What is this condition called?

(b) When does it happen?

(c) Name the type of lens often required by the suffering from this defect. Draw labelled diagram of such lenses. [3]

Answer:

(a) This condition is called presbyopia.

(b) It happens in old age.

(c) Bifocal lens is required for clear vision by the person suffering from presbyopia.

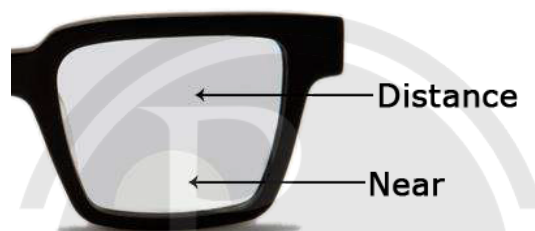

24. How will you use two identical glass prisms so that a narrow beam of white light incident on one prism emerges out of the second prism as white light? Draw and label the ray diagram. [3]

Answer: One glass prism must be placed in inverted position with respect to other, when white light passes through first prism, dispersion happens and white light splits into seven colour. When these colour light falls on the inverted prism, then light of seven colours combine to give white light.

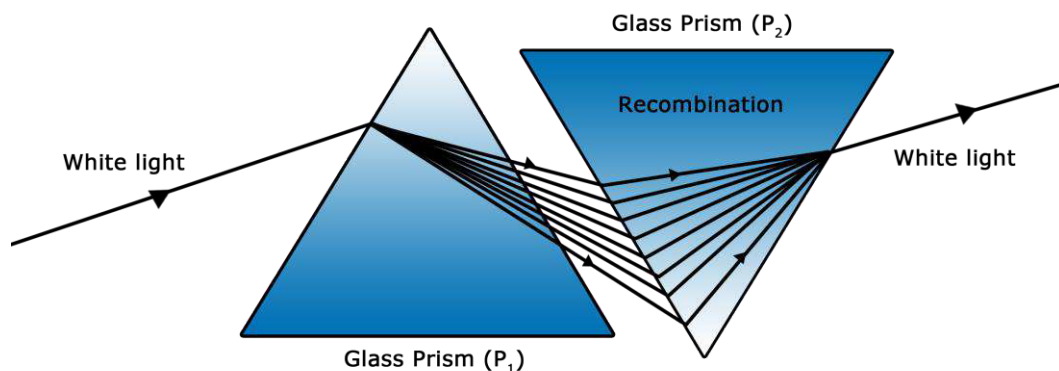

SECTION-C

25. A cloth strip dipped in onion juice is used for testing a liquid 'X'. The liquid 'X' changes its odour. Which type of an indicator is onion juice? 'The liquid 'X' turns blue litmus red. List the observations the liquid 'X' will show on reacting with the following:

(a) Zinc granules

(b) Solid sodium carbonate

Write the chemical equations for the reactions involved. [5]

Answer: Onion juice is an olfactory indicator. Since the liquid 'X' turns blue litmus red, therefore, it is an acid.

(a) When liquid 'X' (an acid like HCl) reacts with zinc granules, bubbles of hydrogen will be formed.

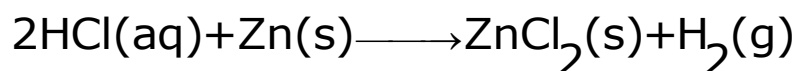

(b) When liquid 'X' (an acid like HCl) reacts with sodium carbonate, carbon dioxide gas will be liberated.

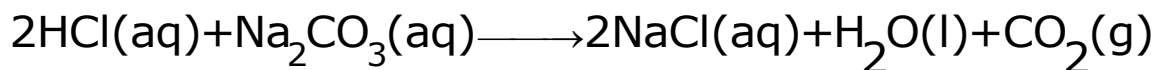

OR

Define water of crystallization. Give the chemical formula for two compounds as examples. How can it be proved that the water of crystallization makes a difference in the state and colour of the compounds? [5]

Answer: Water of crystallisation is the number of molecules of water which are loosely bonded to one molecule of salt.

For example:

- (1) $\text{BaCl}_2 \cdot 2\text{H}_2\text{O}$
- (2) $\text{CuSO}_4 \cdot 5\text{H}_2\text{O}$

We can prove that by heating the compound containing water of crystallisation, its colour or state change due to the removal of water of crystallisation.

For example

- (1) Copper sulphate crystals containing water of crystallisation are blue but on heating they turn white.
- (2) Similarly plaster of Paris is a white powder and on mixing with water it changes to gypsum which forms a hard solid mass.

26. (a) (i) Write two properties of gold which make it the most suitable metal for ornaments.

(ii) Name two metals which are the best conductors of heat.

(iii) Name two metals which melt when you keep them on your palm.

(b) Explain the formation of ionic compound CaO with electron-dot structure. Atomic numbers of calcium and oxygen are 20 and 8 respectively.

[5]

Answer: (a)(i) Gold is inert metal and it has shiny surface. It is also malleable and ductile. Therefore, it is used for making ornaments.

(ii) Copper and aluminium

(iii) Cesium and gallium

(b) The atomic number of calcium and oxygen is 20 and 8 respectively.

The electronic configuration of calcium will be 2, 8, 8, 2 thus, it has 2 electrons in its outermost shell. On the other hand, oxygen (2, 6) has 6 electrons in its outermost shell. By losing two electrons, calcium atom forms a calcium ion (Ca^{2+}) while by gaining 2 electrons; oxygen atom forms an oxide ion (O^{2-}). Calcium reacts with oxygen to form an ionic compound calcium oxide (CaO).

The electron dot representation for the formation of calcium oxide is given below.

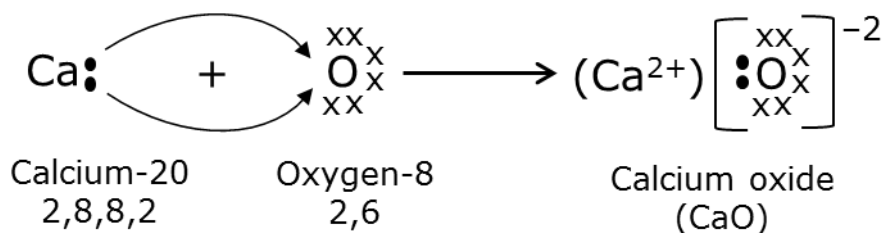

- 27. (a) Why is nutrition necessary for the human body?**
- (b) What causes movement of food inside the alimentary canal?**
- (c) Why is small intestine in herbivores longer than in carnivores?**
- (d) What will happen if mucus is not secreted by the gastric glands?**

[5]

Answer: (a) We obtain nutrition from the food we eat. This nutrition provides us energy for survival, growth and reproduction.

(b) Peristalsis mainly causes the movement of food inside the alimentary canal.

It is defined as a series of wave-like muscular contractions that propels the food inside an alimentary canal.

(c) The small intestine in herbivores is longer than in carnivores because herbivores are plant-eating animals. Plants are made up of cellulose and fibres which are not easily digested.

Therefore, for complete digestion of food, they require a longer digestive tract.

Also, many small bacteria are present in the intestine of herbivores that help in the breakdown of cellulose into glucose. This glucose is used by them as an energy source.

- (d) The gastric glands present in the stomach secrete hydrochloric acid, an enzyme – pepsin, and mucus. Hydrochloric acid provides an acidic medium for the enzyme to function. Pepsin digests proteins into smaller peptides. The mucus provides protection to the inner lining of the stomach from the action of the acid.

If mucus is not secreted by the gastric glands, it may erode the inner lining of the stomach resulting in ulcer and acidity.

28. Draw a neat diagram showing fertilisation in a flower and label (a) pollen tube, (b) male germ cell, (c) female germ cell. Explain the process of fertilisation in a flower. What happens to the (i) ovary and (ii) ovule after fertilisation? [5]

Answer:

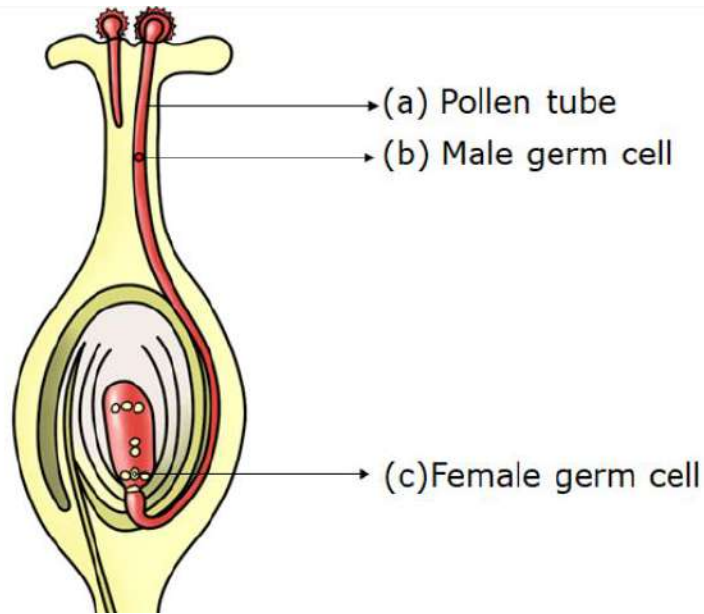

Germination of Pollen on Stigma

When a mature pollen grain reaches the stigma of a flower, it absorbs the sugary secretions of the stigma, swells up and ruptures.

It divides and releases two male gametes, which move down the style to reach the ovary via pollen tube.

On entering the ovule of the ovary through a small opening, called micropyle, one of the male gamete fuses with the female gamete to form a zygote by the process of fertilisation. The other one fuses with the two polar nuclei by the process called triple fusion. Since the fertilisation has occurred twice, it is said that angiospermic plants undergo double fertilisation.

Post fertilisation,

- (i) Ovary develops into fruit
- (ii) Ovule develops into seed

OR

(a) What is puberty?

(b) Describe in brief the functions of the following parts in the human male reproductive system:

(i) Testes

(ii) Seminal vesicle

(iii) Vas deferens

(iv) Urethra

(c) Why are testes located outside the abdominal cavity?

(d) State how sperms move towards the female germ cell.

[5]

Answer:

- (a) The age at which sex hormones begin to produce and reproductive organs of both male and female become functional is termed as puberty. At puberty, both male and female become sexually mature.
- (b) (i) Testes: Testes produce male sex cells called sperms and male sex hormone called testosterone.
(ii) Seminal vesicle: Seminal vesicles store sperms and add seminal fluids to the sperms that make their transport easier. The seminal fluids also provide nutrition to the sperms.

- (iii) Vas deferens: Vas deferens manages the transportation of the mature sperms to the urethra.
- (iv) Urethra : Urethra is a common passage for both urine and sperm. At a time, either of these two fluids are released from the body.
- (c) A pair of testes is located outside the abdominal cavity in a pouch-like structure called scrotum to provide accurate temperature for the process of spermatogenesis. The process of spermatogenesis requires $2-3^{\circ}\text{C}$ less than the body temperature.
- (d) Sperms have a long tail that helps them move towards the female germ-cell.

29. Draw a schematic diagram of a circuit consisting of a battery of 3 cells of 2 V each, a combination of three resistors of $10\ \Omega$, $20\ \Omega$ and $30\ \Omega$ connected in parallel, a plug key and an ammeter, all connected in series. Use this circuit to find the value of the following :

(a) Current through each resistor

(b) Total current in the circuit

(c) Total effective resistance of the circuit [5]

Answer:

Circuit diagram :

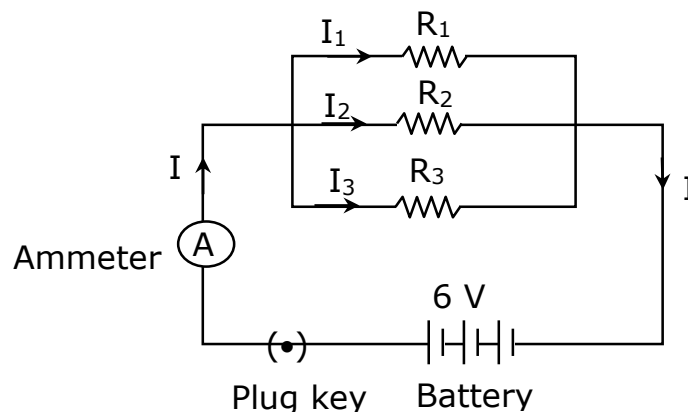

Given:

Voltage in the circuit = $2\text{ V} + 2\text{ V} + 2\text{ V} = 6\text{ V}$

Resistance, $R_1 = 10\ \Omega$, $R_2 = 20\ \Omega$ and $R_3 = 30\ \Omega$

Let I be the total current flowing in the circuit and R be the total effective resistance of the circuit.

According to Ohm's law, $V = IR$

(a) Let electric current flowing through $10\ \Omega$, $20\ \Omega$ and $30\ \Omega$ resistors be I_1 , I_2 and I_3 respectively.

According to Ohm's law, $V = IR$

$$I_1 = \frac{6\text{ V}}{10\ \Omega} = 0.6\text{ A}$$

$$I_2 = \frac{6\text{ V}}{20\ \Omega} = 0.3\text{ A}$$

$$I_3 = \frac{6\text{ V}}{30\ \Omega} = 0.2\text{ A}$$

(b) Total current flowing in the circuit,

$$I = I_1 + I_2 + I_3$$

$$\therefore I = 0.6\text{ A} + 0.3\text{ A} + 0.2\text{ A} = 1.1\text{ A}$$

(c) Total effective resistance of the circuit, $R = \frac{V}{I}$

$$\Rightarrow R = \frac{6\text{ V}}{1.1\text{ A}} = 5.45\ \Omega$$

OR

Two identical resistors, each of resistance 12Ω , are connected in (i) series, and (ii) parallel, in turn to a battery of 6 V . Calculate the ratio of the power consumed in the combination of resistors in each case. [5]

Answer:

Given:

Voltage in the circuit = 6 V

Resistance, $R_1 = R_2 = 15 \Omega$

(i) When the two resistances connected in series:

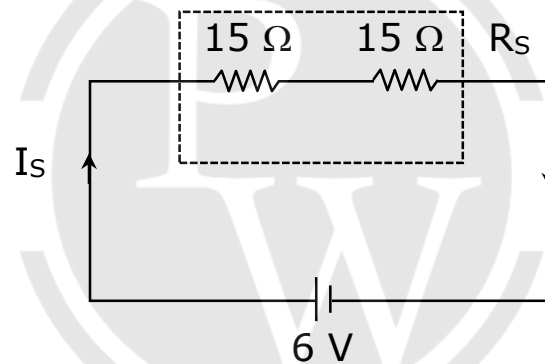

Effective resistance of the circuit, $R_s = R_1 + R_2$

$$R_s = 15 \Omega + 15 \Omega = 30 \Omega$$

Power consumed by the circuit, $P_s = \frac{V^2}{R_s}$

$$\Rightarrow P_s = \frac{(6 \text{ V})^2}{30 \Omega} = 1.2 \text{ W}$$

(ii) When the two resistances connected in parallel:

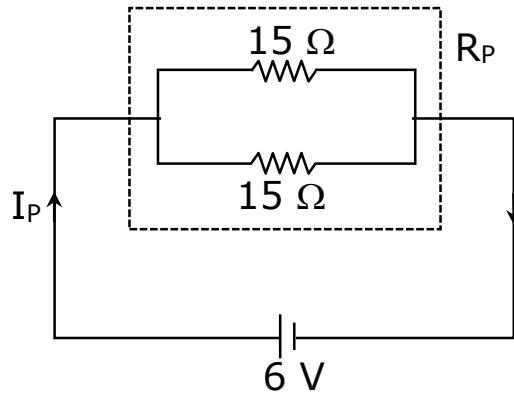

Effective resistance of the circuit, $\frac{1}{R_p} = \frac{1}{R_1} + \frac{1}{R_2}$

$$\Rightarrow \frac{1}{R_p} = \frac{1}{15\ \Omega} + \frac{1}{15\ \Omega} = \frac{1}{30\ \Omega}$$

Power consumed by the circuit, $P_p = \frac{V^2}{R_p}$

$$\Rightarrow P_p = \frac{(6\ \text{V})^2}{30\ \Omega} = 1.2\ \text{W}$$

\therefore Ratio = $P_S : P_p = 1.2\ \text{W} : 1.2\ \text{W} = 1 : 1$

So, the ratio of power consumption is 1:1.

30. (a) State Fleming's Left-hand rule.

(b) List three characteristic features of the electric current used in our homes.

(c) What is a fuse ? Why is it called a safety device ?

(d) Why is it necessary to earth metallic electric appliances ?

[5]

Answer:

(a) Fleming's left-hand rule states that if we stretch the thumb, the forefinger and the middle finger of our left hand in mutually perpendicular directions such that the forefinger gives the direction of current, middle finger points in the direction of magnetic field, then gives the direction of the force or motion of the conductor.

(b) The electric current supplied to our home is alternating in nature. It has following characteristics.

1. It is time varying current.
2. It has frequency of 50 Hz in India.
3. It can be transferred to long distances efficiently.

(c) Fuse is a safety device used in electrical circuit and appliances. It is called safety device because it prevents damage to the appliances and the electrical circuit due to overloading.

(d) The metallic electric appliances are earthed using earth wire as it provides a low resistance path to electric current thus ensuring that any leakage current to the metallic body of the appliance keeps its potential to that of the earth, and the user may not get a severe electric shock.