



KCET Test–2021

PYQ

Physics

1. For a body moving along a straight line, the following $v-t$ graph is obtained. According to the graph, the displacement during

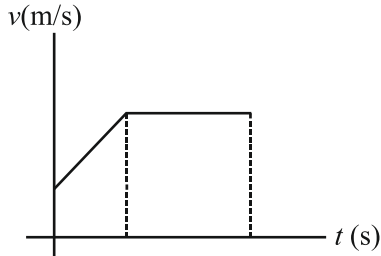

- (A) Uniform acceleration is greater than that during uniform motion
 (B) Uniform acceleration is less than that during uniform motion
 (C) Uniform acceleration is equal to that during uniform motion
 (D) Uniform motion is zero

2. A particle starts from rest. Its acceleration ' a ' versus time ' t ' is shown in the figure. The maximum speed of the particle will be

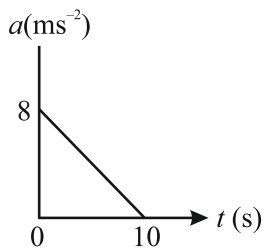

- (A) 80 ms^{-1} (B) 40 ms^{-1}
 (C) 18 ms^{-1} (D) 2 ms^{-1}
3. The maximum range of a gun on horizontal plane is 16 km. If $g = 10 \text{ ms}^{-2}$, then muzzle velocity of a shell is
- (A) 160 ms^{-1} (B) $200\sqrt{2} \text{ ms}^{-1}$
 (C) 400 ms^{-1} (D) 800 ms^{-1}
4. The trajectory of a projectile is
- (A) Semicircle
 (B) An ellipse
 (C) A parabola always
 (D) A parabola in the absence of air resistance

5. For a projectile motion, the angle between the velocity and acceleration is minimum and acute at
- (A) only one point (B) two points
 (C) three points (D) four points
6. A particle starts from the origin at $t = 0$ s with a velocity of $10\hat{j} \text{ ms}^{-1}$ and moves in the x - y plane with a constant acceleration of $(8\hat{i} + 2\hat{j}) \text{ ms}^{-1}$. At an instant when the x -coordinate of the particle is 16 m, y -coordinate of the particle is
- (A) 16 m (B) 28 m
 (C) 36 m (D) 24 m
7. A coin placed on a rotating turn table just slips if it is placed at a distance of 4 cm from the centre. If the angular velocity of the turn table is doubled it will just slip at a distance of
- (A) 1 cm (B) 2 cm
 (C) 4 cm (D) 4 cm
8. A 1 kg ball moving at 12 ms^{-1} collides with a 2 kg ball moving in opposite direction at 24 ms^{-1} . If the coefficient of restitution is $\frac{2}{3}$, then their velocities after the collision are
- (A) $-4 \text{ ms}^{-1}, -28 \text{ ms}^{-1}$
 (B) $-28 \text{ ms}^{-1}, -4 \text{ ms}^{-1}$
 (C) $4 \text{ ms}^{-1}, 28 \text{ ms}^{-1}$
 (D) $28 \text{ ms}^{-1}, 4 \text{ ms}^{-1}$
9. A ball hits the floor and rebounds after an inelastic collision. In this case
- (A) The momentum of the ball is conserved
 (B) The mechanical energy of the ball is conserved
 (C) The total momentum of the ball and the earth is conserved
 (D) The total mechanical energy of the ball and the earth is conserved



10. In figure E and v_{cm} represent the total energy and speed of centre of mass of an object of mass 1 kg in pure rolling. The object is

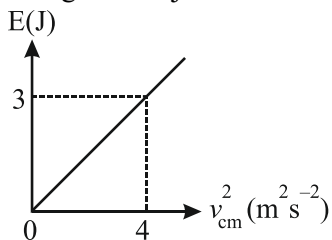

- (A) Sphere (B) Ring
(C) Disc (D) Hollow Cylinder
11. Two bodies of masses 8 kg are placed at the vertices A and B of an equilateral triangle ABC. A third body of mass 2 kg is placed at the centroid G of the triangle. If $AG = BG = CG = 1$ m, where should a fourth body of mass 4 kg be placed so that the resultant force on the 2 kg body is zero?

- (A) at C
(B) at a point P on the line CG such that $PG = \frac{1}{\sqrt{2}}m$
(C) at a point P on the line CG such that $PG = 0.5$ m
(D) at a point P on the line CG such that $PG = 2$ m

12. Two capillary tubes P and Q are dipped vertically in water. The height of water level in capillary tube P is $\frac{2^{\text{th}}}{3}$ of the height in capillary tube Q.

The ratio of their diameter is _____.

- (A) 2 : 3 (B) 3 : 2
(C) 3 : 4 (D) 4 : 3
13. Which of the following curves represent the variation of coefficient of volume expansion of an ideal gas at constant pressure?

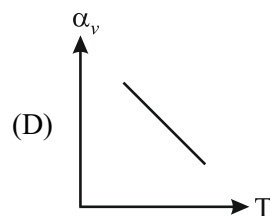
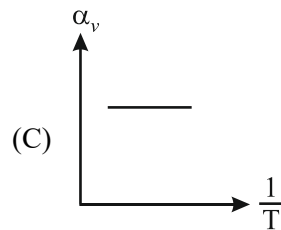
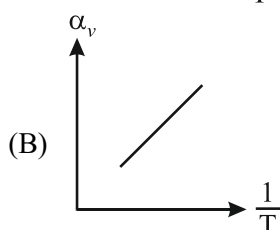
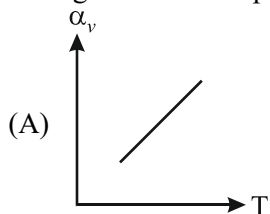

14. A number of Carnot engines are operated at identical cold reservoir temperatures (T_1). However, their hot reservoir temperatures are kept different. A graph of the efficiency of the engines versus hot reservoir temperature (T_H) is plotted. The correct graphical representation is

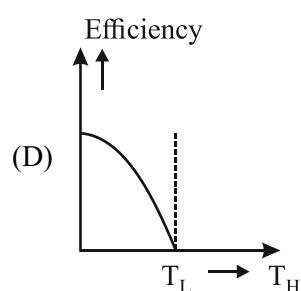
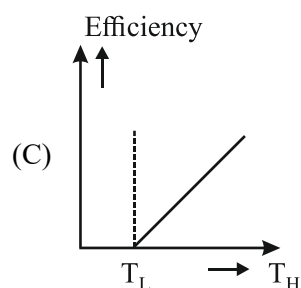
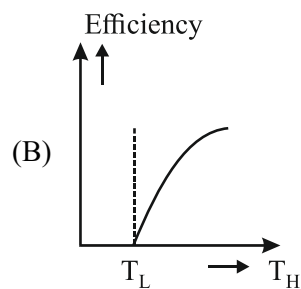
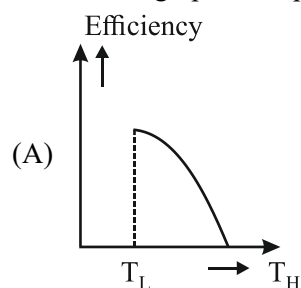



15. A gas mixture contains monoatomic and diatomic molecules of 2 moles each. The mixture has a total internal energy of (symbols have usual meanings)
- (A) 3 RT (B) 5 RT
(C) 8 RT (D) 9 RT
16. A pendulum oscillates simple harmonically if and only if
- (i) the size of the bob of pendulum is negligible in comparison with the length of the pendulum
(ii) the angular amplitude is less than 10°
- (A) Both (i) and (ii) are correct
(B) Both (i) and (ii) are incorrect
(C) Only (i) is correct
(D) Only (ii) is correct
17. To propagate both longitudinal and transverse waves, a material must have
- (A) Bulk and shear moduli
(B) Only bulk modulus
(C) Only shear modulus
(D) Young's and Bulk modulus
18. A copper rod AB of length l is rotated about end A with a constant angular velocity ω . The electric field at a distance x from the axis of rotation is
- (A) $\frac{m\omega^2 x}{e}$ (B) $\frac{m\omega x}{el}$
(C) $\frac{mx}{\omega^2 l}$ (D) $\frac{me}{\omega^2 x}$
19. Electric field due to infinite, straight uniformly charged wire varies with distance ' r ' as
- (A) r (B) $\frac{1}{r}$
(C) $\frac{1}{r^2}$ (D) r^2
20. A 2-gram object, located in a region of uniform electric field $\vec{E} = (300\text{NC}^{-1})\hat{i}$ carries a charge Q . The object released from rest at $x = 0$, has a kinetic energy of 0.12 J at $x = 0.5$ m. Then Q is
- (A) 400 μC (B) -400 μC
(C) 800 μC (D) -800 μC
21. If a slab of insulating material (conceptual) 4×10^{-3} m thick is introduced between the plates of a parallel plate capacitor, the separation between the plates has to be increased by 3.5×10^{-3} m to restore the capacity to original value. The dielectric constant of the material will be
- (A) 6 (B) 8
(C) 10 (D) 12
22. Eight drops of mercury of equal radii combine to form a big drop. The capacitance of a bigger drop as compared to each smaller drop is
- (A) 2 times (B) 8 times
(C) 4 times (D) 16 times
23. Which of the statements is false in the case of polar molecules?
- (A) Centres of positive and negative charges are separated in the absence of external electric field
(B) Centres of positive and negative charges are separated in the presence of external electric field
(C) Do not possess permanent dipole moments
(D) Ionic molecule HCl is the example of polar molecule
24. An electrician requires a capacitance of 6 μF in a circuit across a potential difference of 1.5 kV. A large number of 2 μF capacitors which can withstand a potential difference of not more than 500 V are available. The minimum number of capacitors required for the purpose is
- (A) 3 (B) 9
(C) 6 (D) 27



25. In figure, charge on the capacitor is plotted against potential difference across the capacitor. The capacitance and energy stored in the capacitor are respectively

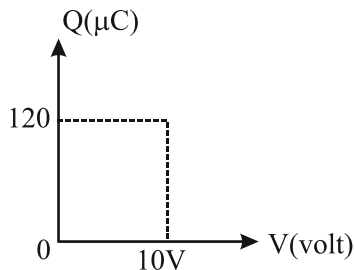

- (A) $12 \mu\text{F}$, $1200 \mu\text{J}$
 (B) $12 \mu\text{F}$, $600 \mu\text{J}$
 (C) $24 \mu\text{F}$, $600 \mu\text{J}$
 (D) $24 \mu\text{F}$, $1200 \mu\text{J}$
26. A wire of resistance 3Ω is stretched to twice its original length. The resistance of the new wire will be
- (A) 1.5Ω
 (B) 3Ω
 (C) 6Ω
 (D) 12Ω
27. In the given arrangement of experiment on metre bridge. If AD corresponding to null deflection of the galvanometer is x , what would be its value if radius of the wire AB is doubled?

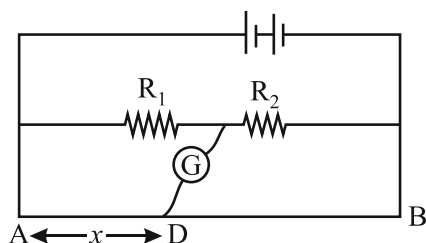

- (A) x
 (B) $\frac{x}{4}$
 (C) $4x$
 (D) $2x$

28. A copper wire of length 1 m and uniform cross-sectional area $5 \times 10^{-7} \text{ m}^2$ carries a current of 1 A . Assuming that there are 8×10^{28} free electrons per m^3 in copper, how long will an electron take to drift from one end of the wire to the other?

- (A) $0.8 \times 10^3 \text{ s}$
 (B) $1.6 \times 10^3 \text{ s}$
 (C) $3.2 \times 10^2 \text{ s}$
 (D) $6.4 \times 10^3 \text{ s}$

29. Consider an electrical conductor connected across a potential difference V . Let Δq be a small charge moving through it in time Δt . If I is the electric current through it,

- (i) the kinetic energy of the charge increases by $IV \Delta t$
 (ii) the electric potential energy of the charge decreases by $IV \Delta t$
 (iii) the thermal energy of the conductor increases by $IV \Delta t$

Then the correct statement/s is/are

- (A) (I)
 (B) (I), (II)
 (C) (I) and (III)
 (D) (II) and (III)

30. A strong magnetic field is applied on a stationary electron. Then the electron

- (A) Moves in the direction of the field
 (B) Moves in an opposite direction of the field
 (C) Remains stationary
 (D) Starts spinning

31. Two parallel wires in free space are 10 cm apart and each wire carries a current of 10 A in the same direction. The force exerted by one wire on the other [per unit length] is

- (A) $2 \times 10^{-4} \text{ N m}^{-1}$ [attractive]
 (B) $2 \times 10^{-2} \text{ N m}^{-1}$ [attractive]
 (C) $2 \times 10^{-4} \text{ N m}^{-1}$ [repulsive]
 (D) $2 \times 10^{-2} \text{ N m}^{-1}$ [repulsive]



32. A toroid with thick windings of N turns has inner and outer radii R_1 and R_2 respectively. If it carries certain steady current i , the variation of the magnetic field due to the toroid with radial distance is correctly graphed in

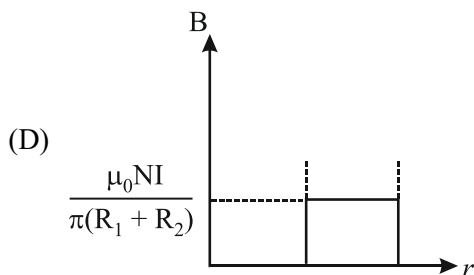
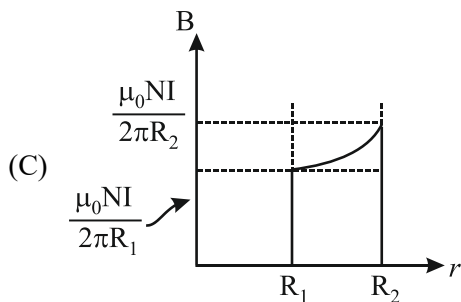
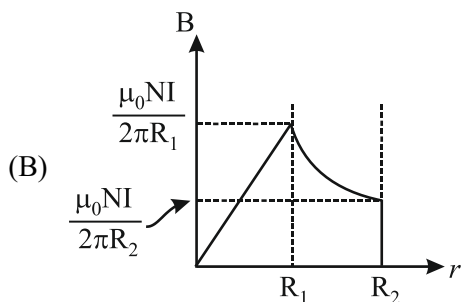
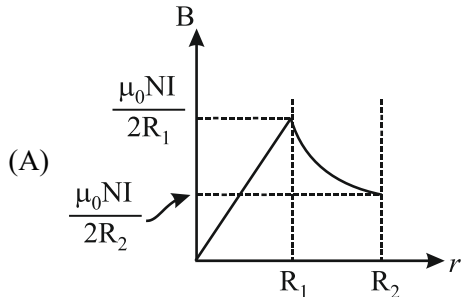

33. A tightly wound long solenoid has ' n ' turns per unit length, a radius ' r ' and carries a current I . A particle having charge ' q ' and mass ' m ' is projected from a point on the axis in a direction perpendicular to the axis. The maximum speed of the particle for which the particle does not strike the solenoid is

- (A) $\frac{\mu_0 n I q r}{m}$ (B) $\frac{\mu_0 n I q r}{2m}$
 (C) $\frac{\mu_0 n I q r}{4m}$ (D) $\frac{\mu_0 n I q r}{8m}$

34. Earth's magnetic field always has a horizontal component except at

- (A) equator
 (B) magnetic poles
 (C) a latitude of 60°
 (D) an altitude of 60°

35. Which of the field pattern given below is valid for electric field as well as for magnetic field?

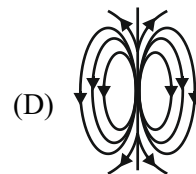
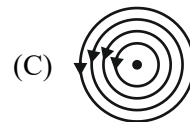
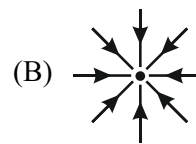
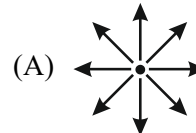

36. The current flowing through an inductance coil of self inductance 6 mH at different time instants is as shown. The emf induced between $t = 20 \text{ s}$ and $t = 40 \text{ s}$ is nearly

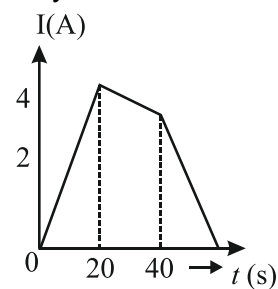

- (A) $2 \times 10^{-2} \text{ V}$ (B) $3 \times 10^{-2} \text{ V}$
 (C) $4 \times 10^{-3} \text{ V}$ (D) $30 \times 10^2 \text{ V}$

37. The physical quantity which is measured in the unit of Wb A^{-1} is

- (A) Self-inductance
 (B) Mutual inductance
 (C) Magnetic flux
 (D) Both (A) and (B)



38. What will be the reading in the voltmeter and ammeter of the circuit shown?

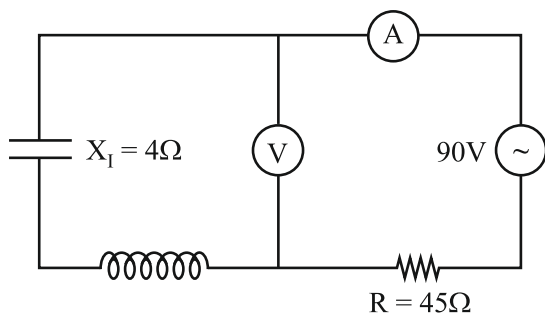

- (A) 90 V, 2 A (B) 0 V, 2 A
(C) 90 V, 1 A (D) 0 V, 1 A
39. LC oscillations are similar and analogous to the mechanical oscillations of a block attached to a spring. The electrical equivalent of the force constant of the spring is
- (A) reciprocal of capacitive reactance
(B) capacitive reactance
(C) reciprocal of capacitance
(D) capacitance
40. In an oscillating LC circuit, $L = 3.00$ mH and $C = 2.70$ μ F. At $t = 0$, the charge on the capacitor is zero and the current is 2.00 A. The maximum charge that will appear on the capacitor will be
- (A) 1.8×10^{-5} C (B) 18×10^{-5} C
(C) 9×10^{-5} C (D) 90×10^{-5} C
41. Suppose that the electric field amplitude of electromagnetic wave is $E_a = 120$ N C⁻¹ and its frequency is $f = 50$ MHz. Then which of the following value is incorrectly computed?
- (A) Magnetic field amplitude is 400 nT
(B) Angular frequency of EM wave is $\pi \times 10^8$ rads⁻¹
(C) Propagation constant (angular wave number) is 2.1 rad m⁻¹
(D) Wavelength of the EM wave is 6 m
42. The source of electromagnetic waves can be a charge
- (A) Moving with a constant velocity
(B) Moving in a circular orbit
(C) At rest
(D) Moving parallel to the magnetic field

43. In refraction, light waves are bent on passing from one medium to second medium because in the second medium

(A) requery is different
(B) speed is different
(C) coefficient of elasticity is different
(D) amplitude is smaller

44. If the refractive index from air to glass is $\frac{3}{2}$ and

that from air to water is $\frac{4}{3}$, then the ratio of focal lengths of a glass lens in water and in air is

(A) 1 : 2 (B) 2 : 1
(C) 1 : 4 (D) 4 : 1

45. Two thin biconvex lenses have focal lengths f_1 and f_2 . A third thin biconcave lens has focal length of f_3 . If the first two biconvex lenses are kept in contact, the total power of the lenses is P_1 . If the first convex lens is in contact with the third lens, the total power is P_2 . If the second lens is kept in contact with the third lens, the total power is P_3 , then

(A) $P_1 = \frac{f_1 f_2}{f_1 - f_2}$, $P_2 = \frac{f_1 f_2}{f_2 - f_1}$ and $P_3 = \frac{f_2 f_3}{f_3 - f_2}$

(B) $P_1 = \frac{f_1 - f_2}{f_1 f_2}$, $P_2 = \frac{f_3 - f_1}{f_3 + f_1}$ and $P_3 = \frac{f_3 - f_2}{f_2 f_3}$

(C) $P_1 = \frac{f_1 - f_2}{f_1 f_2}$, $P_2 = \frac{f_3 - f_1}{f_1 f_2}$ and $P_3 = \frac{f_3 - f_2}{f_2 f_3}$

(D) $P_1 = \frac{f_1 + f_2}{f_1 f_2}$, $P_2 = \frac{f_2 - f_1}{f_1 f_3}$ and $P_3 = \frac{f_3 - f_2}{f_2 f_3}$

46. The size of the image of an object, which is at infinity, as formed by a convex lens of focal length 30 cm is 2 cm. If a concave lens of focal length 20 cm is placed between the convex lens and the image at a distance of 26 cm from the lens, the new size of the image is

(A) 1.25 cm (B) 2.5 cm
(C) 1.05 cm (D) 2 cm



47. A slit of width ' a ' is illuminated by red light of wavelength 6500 \AA . If the first diffraction minimum falls at 30° , then the value of ' a ' is
 (A) $6.5 \times 10^{-4} \text{ mm}$ (B) 1.3 micron
 (C) 3250 \AA (D) $2.6 \times 10^{-4} \text{ cm}$

48. Which of the statements are correct with reference to single slit diffraction pattern?

- (i) Fringes are of unequal width
 (ii) Fringes are of equal width
 (iii) Light energy is conserved
 (iv) Intensities of all bright fringes are equal
 (A) (i) and (iii) (B) (i) and (iv)
 (C) (ii) and (iv) (D) (ii) and (iii)

49. In the YDSE, a monochromatic source of wavelength λ is used. The intensity of light passing through each slit is I_0 . The intensity of light reaching the screen S_C at a point P, a distance x from O is given by (Take $d \ll D$)

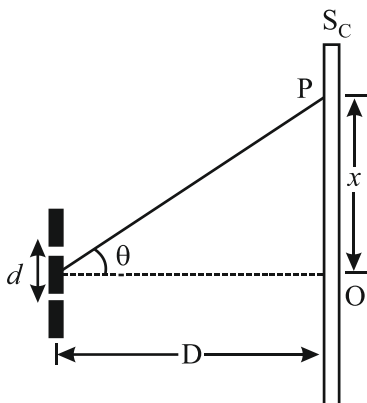

- (A) $I_0 \cos^2 \left(\frac{\pi D}{\lambda d} x \right)$
 (B) $4I_0 \cos^2 \left(\frac{\pi d}{\lambda D} x \right)$
 (C) $I_0 \sin^2 \left(\frac{\pi d}{2\lambda D} x \right)$
 (D) $4I_0 \cos \left(\frac{x d}{2\lambda D} x \right)$

50. The work function of a metal is 1 eV. Light of wavelength 3000 \AA is incident on this metal surface. The maximum velocity of emitted photoelectrons will be about
 (A) 10 ms^{-1} (B) $1 \times 10^3 \text{ ms}^{-1}$
 (C) $1 \times 10^4 \text{ ms}^{-1}$ (D) $1 \times 10^6 \text{ ms}^{-1}$

51. A proton moving with a momentum P_1 has a kinetic energy $\frac{1}{8}$ of its rest mass energy. Another light photon having energy equal to the kinetic energy of the proton possesses a momentum P_2 . Then the ratio $\frac{P_1 - P_2}{P_1}$ is equal to

- (A) 1 (B) $\frac{1}{4}$
 (C) $\frac{1}{2}$ (D) $\frac{3}{4}$

52. According to Einstein's photoelectric equation, the graph between kinetic energy of photoelectrons ejected and the frequency of incident radiation is

