



2024 - 25

Current Electricity

Recall what did you study in previous class

Electric current

- $I = \frac{Q \text{ coulomb}}{t \text{ second}} = \text{ampere}$
- Ampere is the unit of current. If i is not constant then $i = \frac{dq}{dt}$, where dq is net charge transported at a section in time dt .

Electric Current in A Conductor

- $i = nv_d eA$, where $v_d =$ drift velocity.

Current Density

- $\vec{J} = \frac{i}{S} \vec{n}$ or $i = \vec{J} \cdot \vec{S}$ where \vec{n} is the unit vector in the direction of the flow of current.

Relation between J, E and V_d

- In conductors drift velocity of electrons is proportional to the electric field inside the conductor as; $v_d = \mu E$ where μ is the mobility of electrons

Current density is given as $J = \frac{I}{A} = nev_d = ne(\mu E) = \sigma E$

where $\sigma = ne\mu$ is called conductivity of material and we can also write $\rho = \frac{1}{\sigma} \rightarrow$ resistivity of material

Thus $\vec{E} = \rho \vec{J}$. It is called as differential form of Ohm's Law.

Electrical Resistance

Law of Resistance

- The resistance R offered by a conductor depends on the following factors:
- $R \propto \ell$ (length of the conductor); $\frac{1}{R} \propto \frac{1}{A}$ (cross section area of the conductor).
- At a given temperature, $R = \rho \frac{\ell}{A}$
- where ρ is the resistivity of the material of the conductor at the given temperature. It is also known as specific resistance of the material & it depends upon nature of conductor.

Dependence of Resistance on Temperature

- The resistance of most conductors and all pure metals increases with temperature. If R_0 & R be the resistance of a conductor at 0°C and $\theta^\circ\text{C}$, then it is found that $R = R_0 (1 + \alpha\theta)$
- Resistivity also depends on temperature as, $\rho = \rho_0 (1 + \alpha\theta)$.
- Where α is called the temperature co-efficient of resistance.



- The unit of α is K^{-1} or $^{\circ}C^{-1}$. Reciprocal of resistivity is called conductivity and reciprocal of resistance is called conductance (G). S.I. unit of G is mho.
- The materials for which resistance decreases with temperature, the temperature coefficient of resistance is negative.

OHM'S Law

It says that the current through the cross section of the conductor is proportional to the applied potential difference under the given physical condition. $V = RI$. Ohm's law is applicable to only metallic conductors.

Krichhoff's Law's

I - Law (Junction law or Nodal Analysis): This law is based on law of conservation of charge.

$$\sum I_{in} = \sum I_{out}$$

It is also known as KCL (Kirchhoff's current law).

II - Law (Loop analysis): The algebraic sum of all the voltages in closed circuit is zero. $\sum IR + \sum EME = 0$ in a closed loop. The closed loop can be traversed in any direction. While traversing a loop if higher potential point is entered, put a positive sign in expression or if lower potential point is entered put a negative sign.

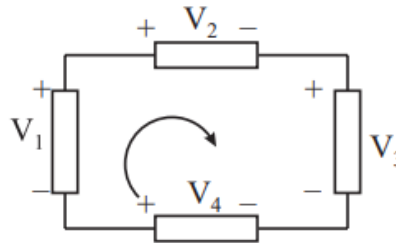

$-V_1 + V_2 + V_3 - V_4 = 0$. Boxes may contain resistor or battery or any other element (linear or non-linear). It is also known as KVL (Kirchhoff's voltage law).

Combination of Resistances

(i) Resistance in Series

When the resistances are connected end to end then they are said to be in series. The current through each resistor is same. The effective resistance appearing across the battery;

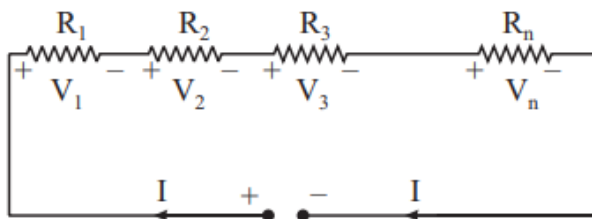

$$R = R_1 + R_2 + R_3 + \dots + R_n \text{ and}$$

$$V = V_1 + V_2 + V_3 + \dots + V_n$$

The voltage across a resistor is proportional to the resistance

$$V_1 = \frac{R_1}{R_1 + R_2 + \dots + R_n} V; V_2 = \frac{R_2}{R_1 + R_2 + \dots + R_n} V$$

(ii) Resistance in Parallel

A parallel circuit of resistors is the one in which the same voltage is applied across all the components.

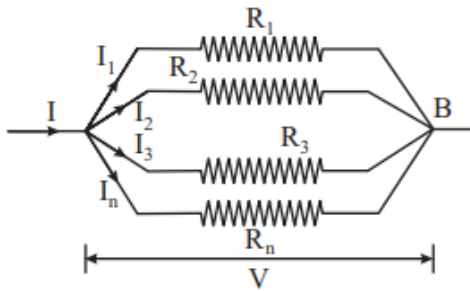

Conclusions

- Potential difference across each resistor is same.
- $I = I_1 + I_2 + I_3 + \dots + I_n$.
- Effective resistance (R) then

$$\frac{1}{R} = \frac{1}{R_1} + \frac{1}{R_2} + \frac{1}{R_3} + \dots + \frac{1}{R_n}$$

- Current in different resistors is inversely proportional to the resistances

$$I_1 : I_2 : \dots : I_n = \frac{1}{R_1} : \frac{1}{R_2} : \frac{1}{R_3} : \dots : \frac{1}{R_n}$$

Emf of a Cell & its internal Resistance

If a cell of emf E and internal resistance r be connected with a resistance R the total resistance of the circuit is $(R + r)$.

$$I = \frac{E}{R + r}; V_{AB} = V = \frac{ER}{R + r}$$

where V_{AB} = Terminal voltage of the battery.

If $r \rightarrow 0$, cell is ideal & $V \rightarrow E$

$$r = R \left(\frac{E}{V} - 1 \right)$$

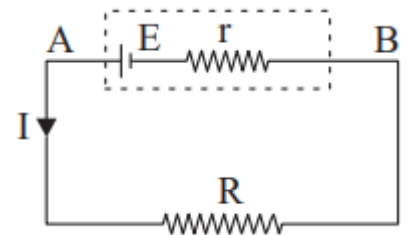

Grouping of Cells

(i) Cells In Series

- Let there be n cells each of emf E , arranged in series. Let r be the internal resistance of each cell. The total emf = nE
- Current in the circuit $I = \frac{nE}{R + nr}$. If $nr \ll R$ then $I \approx \frac{nE}{R}$

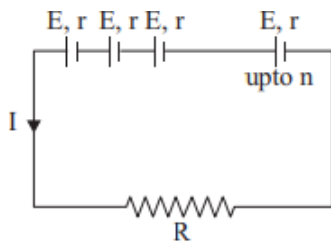

$$\text{If } nr \gg R \text{ then } I = \frac{E}{r}$$

(ii) Cells In Parallel

If m cells each of emf E & internal resistance r be connected in parallel and if this combination be connected to an external resistance (R) then the net emf of the circuit = E .



Net internal resistance of the circuit = $\frac{r}{m}$

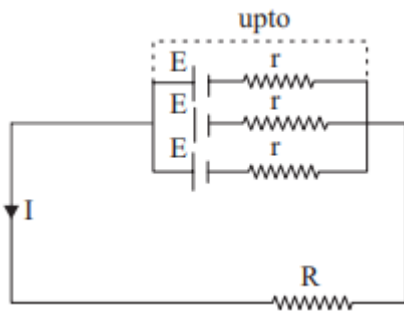

$$I = \frac{E}{R + \frac{r}{m}} = \frac{mE}{mR + r}$$

If $mR \ll r$ then $I = \frac{mE}{r}$

If $mR \gg r$ then $I = \frac{mE}{mR}$

(iii) Cells in Matrix Array:

n = number of rows

m = number of cells in each row

mn = total number of identical cells.

The combination of cells is equivalent to single cell of:

(a) emf = nE &

(b) Internal resistance = $\frac{mr}{n}$

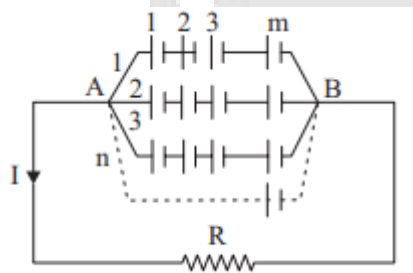

$$\text{Current } I = \frac{nE}{R + \frac{mr}{n}}$$

For maximum power

$$nR = mr \text{ or } R = \frac{mr}{n}$$

$$\text{So } I_{\max} = \frac{nE}{2r} = \frac{mE}{2R}$$

For a cell to deliver maximum power across the load net internal resistance = load resistance

Wheat-stone Network

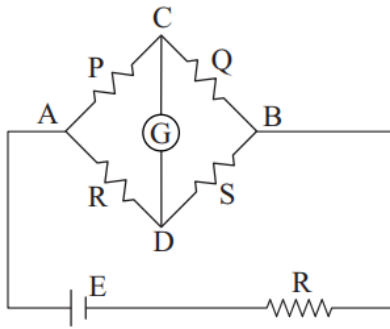

When current through the galvanometer is zero (null point or balance point) $\frac{P}{Q} = \frac{R}{S}$

When,

$PS > QR \Rightarrow V_C < V_D$ $PS < QR \Rightarrow V_C > V_D$

$PS = QR \Rightarrow V_C = V_D$

Metre Bridge

At balance condition:

$$\frac{P}{Q} = \frac{R}{S} \Rightarrow \frac{\ell}{(100-\ell)} = \frac{R}{S} \Rightarrow S = \frac{(100-\ell)}{\ell} R$$

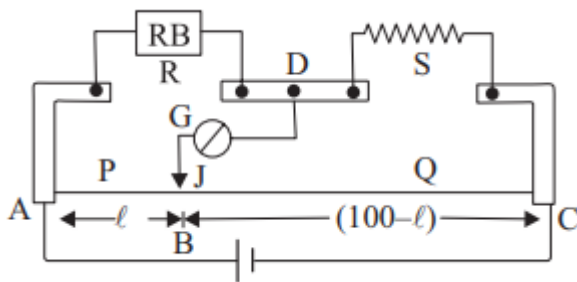

Ammeter

It is used to measure current. A shunt (small resistance) is connected in parallel with galvanometer to convert into ammeter.

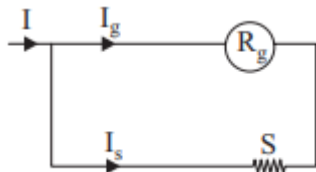

$$S = \frac{I_g R_g}{I - I_g}$$

Where

R_g = galvanometer resistance

I_g = Maximum current that can flow through the galvanometer.

I = Maximum current that can be measured using the given ammeter.

An Ideal ammeter has zero resistance.

Voltmeter

A high resistance is put in series with galvanometer. It is used to measure potential difference.

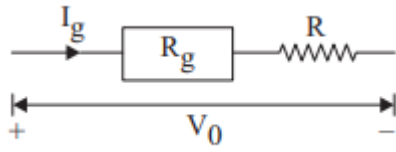

$$I_g = \frac{V_0}{R_g + R}; R \rightarrow \infty, \text{ Ideal voltmeter}$$

$$R = (V_0/I_g) - R_g$$



PW Web/App - <https://smart.link/7wwosivoicgd4>
Library- <https://smart.link/sdfez8ejd80if>