

Physics

1. An induced current of 2 A flows through a coil. The resistance of the coil is 10Ω . What is the change in magnetic flux associated with the coil in 1 ms?
 (A) 0.2×10^{-2} Wb (B) 2×10^{-2} Wb
 (C) 22×10^{-2} Wb (D) 0.22×10^{-2} Wb

2. A square loop of side length 'a' is moving away from an infinitely long current carrying conductor at a constant speed 'v' as shown. Let 'x' be the instantaneous distance between the long conductor and side AB. The mutual inductance (M) of the square loop - long conductor pair changes with time (t) according to which of the following graphs?

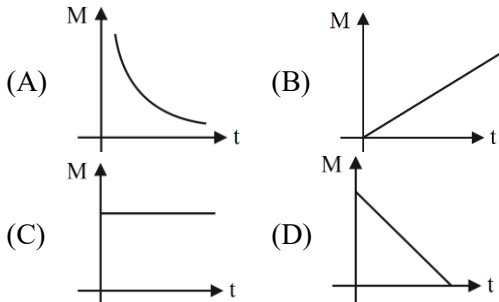
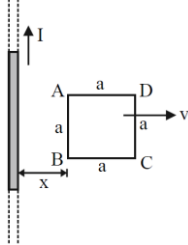

3. Which of the following combinations should be selected for better tuning of an LCR circuit used for communication?
 (A) $R = 20\Omega$, $L = 1.5H$, $C = 35\mu F$
 (B) $R = 25\Omega$, $L = 2.5H$, $C = 45\mu F$
 (C) $R = 25\Omega$, $L = 1.5H$, $C = 45\mu F$
 (D) $R = 15\Omega$, $L = 3.5H$, $C = 30\mu F$
4. In an LCR series circuit, the value of only capacitance C is varied. The resulting variation of resonance frequency f_0 as a function of C can be represented as

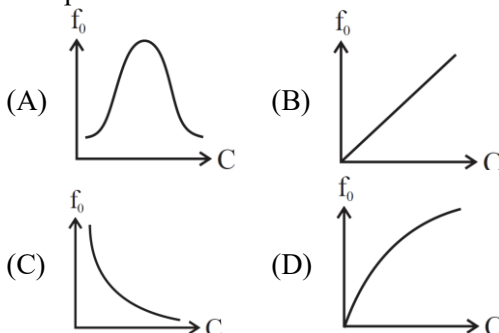

5. The figure shows variation of R , X_L and X_C with frequency 'f' in a series LCR circuit. Then for what frequency point is the circuit capacitive?

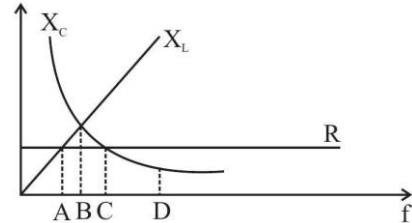

- (A) B (B) C
 (C) A (D) D
6. Electromagnetic waves are incident normally on a perfectly reflecting surface having surface area A. If I is the intensity of the incident electromagnetic radiation and c is the speed of light in vacuum, the force exerted by the electromagnetic wave on the reflecting surface is
 (A) $\frac{2IA}{c}$ (B) $\frac{IA}{c}$
 (C) $\frac{IA}{2c}$ (D) $\frac{I}{2Ac}$
7. The final image formed by an astronomical telescope is
 (A) real, erect and diminished
 (B) virtual, inverted and diminished
 (C) real, inverted and magnified
 (D) virtual, inverted and magnified

8. If the angle of minimum deviation is equal to angle of a prism for an equilateral prism, then the speed of light inside the prism is _____
 (A) $3 \times 10^8 \text{ ms}^{-1}$ (B) $2\sqrt{3} \times 10^8 \text{ ms}^{-1}$
 (C) $\sqrt{3} \times 10^8 \text{ ms}^{-1}$ (D) $\frac{\sqrt{3}}{2} \times 10^8 \text{ ms}^{-1}$

9. A luminous point object O is placed at a distance 2R from the spherical boundary separating two transparent media of refractive indices n_1 and n_2 as shown, where R is the radius of curvature of the spherical surface.

If $n_1 = \frac{4}{3}$, $n_2 = \frac{3}{2}$ and $R = 10 \text{ cm}$, the image is obtained at a distance from P equal to

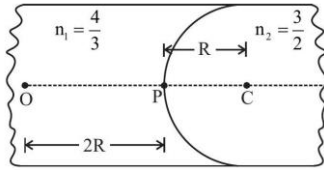

- (A) 30 cm in the rarer medium
 (B) 30 cm in the denser medium
 (C) 18 cm in the rarer medium
 (D) 18 cm in the denser medium

10. An equiconvex lens of radius of curvature 14 cm is made up of two different materials. Left half and right half of vertical portion is made up of material of refractive index 1.5 and 1.2 respectively as shown in the figure. If a point object is placed at a distance of 40 cm, calculate the image distance.

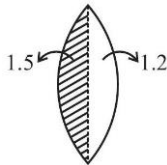

- (A) 25 cm (B) 50 cm
 (C) 35 cm (D) 40 cm

11. A galaxy is moving away from the Earth so that a spectral line at 600 nm is observed at 601 nm. Then the speed of the galaxy with respect to the Earth is
- (A) 500 km s⁻¹ (B) 50 km s⁻¹
 (C) 200 km s⁻¹ (D) 20 km s⁻¹

12. Three polaroid sheets are co-axially placed as indicated in the diagram. Pass axes of the polaroids 2 and 3 make 30° and 90° with pass axis of polaroid sheet 1. If I₀ is the intensity of the incident unpolarised light entering sheet 1, the intensity of the emergent light through sheet 3 is

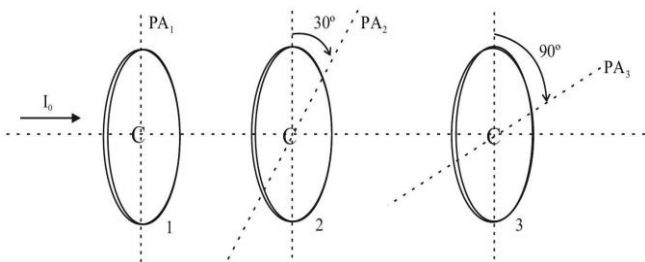

- (A) Zero (B) $\frac{3I_0}{32}$
 (C) $\frac{3I_0}{8}$ (D) $\frac{3I_0}{16}$

13. In Young's double slit experiment, an electron beam is used to produce interference fringes of width β_1 . Now the electron beam is replaced by a beam of protons with the same experimental set-up and same speed. The fringe width obtained is β_2 . The correct relation between β_1 and β_2 is
- (A) $\beta_1 = \beta_2$
 (B) No fringes are formed
 (C) $\beta_1 < \beta_2$
 (D) $\beta_1 > \beta_2$

14. Light of energy E falls normally on a metal of work function $\frac{E}{3}$. The kinetic energies (K) of the photo electrons are

- (A) $K = \frac{2E}{3}$ (B) $K = \frac{E}{3}$
 (C) $0 \leq K \leq \frac{2E}{3}$ (D) $0 \leq K \leq \frac{E}{3}$

15. The photoelectric work function for photo metal is 2.4 eV. Among the four wavelengths, the wavelength of light for which photo-emission does not take place is

- (A) 200 nm (B) 300 nm
 (C) 700 nm (D) 400 nm

16. In alpha particle scattering experiment, if v is the initial velocity of the particle, then the distance of closest approach is d. If the velocity is doubled, then the distance of closest approach becomes

- (A) 4 d (B) 2 d
 (C) $\frac{d}{2}$ (D) $\frac{d}{4}$

17. The ratio of area of first excited state to ground state of orbit of hydrogen atom is

- (A) 1 : 16 (B) 1 : 4
 (C) 4 : 1 (D) 16 : 1

18. The ratio of volume of Al²⁷ nucleus to its surface area is (Given $R_0 = 1.2 \times 10^{-15}$ m)

- (A) 2.1×10^{-15} m (B) 1.3×10^{-15} m
 (C) 0.22×10^{-15} m (D) 1.2×10^{-15} m

19. Consider the nuclear fission reaction

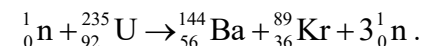

Assuming all the kinetic energy is carried away by the fast neutrons only and total binding energies of ${}_{92}^{235}\text{U}$, ${}_{56}^{144}\text{Ba}$ and ${}_{36}^{89}\text{Kr}$ to be 1800 MeV, 1200 MeV and 780 MeV respectively, the average kinetic energy carried by each fast neutron is (in MeV)

- (A) 200 (B) 180
 (C) 67 (D) 60



20. The natural logarithm of the activity R of a radioactive sample varies with time t as shown. At $t = 0$, there are N_0 undecayed nuclei. Then N_0 is equal to [Take $e^2 = 7.5$]

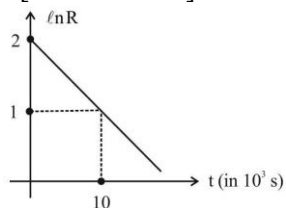

- (A) 7,500 (B) 3,500
(C) 75,000 (D) 1,50,000
21. Depletion region in an unbiased semiconductor diode is a region consisting of
(A) Both free electrons and holes
(B) Neither free electrons nor holes
(C) Only free electrons
(D) Only holes
22. The upper level of valence band and lower level of conduction band overlap in the case of
(A) Silicon (B) Copper
(C) Carbon (D) Germanium
23. In the diagram shown, the Zener diode has a reverse breakdown voltage of V_Z . The current through the load resistance R_L is I_L . The current through the Zener diode is

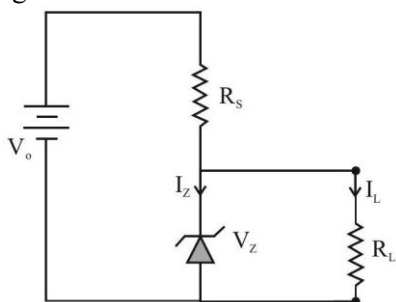

- (A) $\frac{V_0 - V_Z}{R_s}$ (B) $\frac{V_0 - V_Z}{R_L}$
(C) $\frac{V_Z}{R_L}$ (D) $\left(\frac{V_0 - V_Z}{R_s}\right) - I_L$
24. A p-n junction diode is connected to a battery of emf 5 – 7V in series with a resistance $5k\Omega$ such that it is forward biased. If the barrier potential of the diode is 0 – 7V, neglecting the diode resistance, the current in the circuit is
(A) 1.14 mA (B) 1 mA
(C) 1 A (D) 1.14 A

25. Dimensional formula for activity of a radioactive substance is
(A) $M^0 L^1 T^{-1}$ (B) $M^0 L^{-1} T^0$
(C) $M^0 L^0 T^{-1}$ (D) $M^{-1} L^0 T^0$

26. An athlete runs along a circular track of diameter 80 m. The distance travelled and the magnitude of displacement of the athlete when he covers $\frac{3}{4}$ of the circle is (in m)
(A) $60\pi, 40\sqrt{2}$ (B) $40\pi, 60\sqrt{2}$
(C) $120\pi, 80\sqrt{2}$ (D) $80\pi, 120\sqrt{2}$
27. Among the given pair of vectors, the resultant of two vectors can never be 3 units. The vectors are
(A) 1 unit and 2 units
(B) 2 units and 5 units
(C) 3 units and 6 units
(D) 4 units and 8 units

28. A block of certain mass is placed on a rough inclined plane. The angle between the plane and the horizontal is 30° . The coefficients of static and kinetic frictions between the block and the inclined plane are 0.6 and 0.5 respectively. Then the magnitude of the acceleration of the block is [Take $g = 10 \text{ ms}^{-2}$]

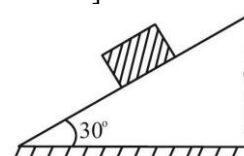

- (A) 2 ms^{-2} (B) zero
(C) 0.196 ms^{-2} (D) 0.67 ms^{-2}
29. A particle of mass 500 g is at rest. It is free to move along a straight line. The power delivered to the particle varies with time according to the following graph :

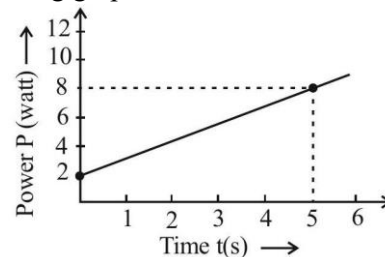

- The momentum of the particle at $t = 5 \text{ s}$ is
(A) $2\sqrt{2} \text{ Ns}$ (B) $5\sqrt{2} \text{ Ns}$
(C) 5 Ns (D) 5.5 Ns



30. A ceiling fan is rotating around a fixed axle as shown. The direction of angular velocity along.

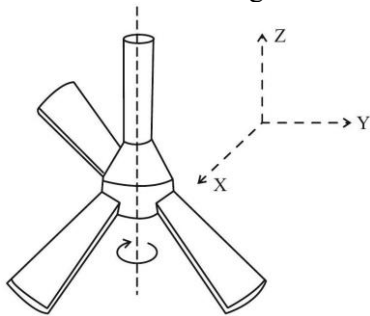

- (A) $+\hat{j}$ (B) $-\hat{j}$
 (C) $+\hat{k}$ (D) $-\hat{k}$
31. A body of mass 1 kg is suspended by a weightless string which passes over a frictionless pulley of mass 2 kg as shown in the figure. The mass is released from a height of 1.6 m from the ground. With what velocity does it strike the ground?

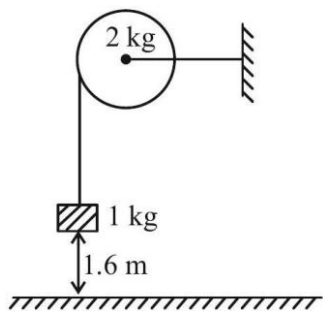

- (A) 16 ms^{-1} (B) 8 ms^{-1}
 (C) $4\sqrt{2} \text{ ms}^{-1}$ (D) 4 ms^{-1}
32. What is the value of acceleration due to gravity at a height equal to half the radius of the Earth, from its surface ?
- (A) 4.4 ms^{-2} (B) 6.5 ms^{-2}
 (C) Zero (D) 9.8 ms^{-2}
33. A thick metal wire of density ρ and length 'L' is hung from a rigid support. The increase in length of the wire due to its own weight is (Y = Young's modulus of the material of the wire)
- (A) $\frac{\rho g L}{Y}$ (B) $\frac{1}{2} \frac{\rho g L^2}{Y}$
 (C) $\frac{\rho g L^2}{Y}$ (D) $\frac{1}{4Y} \rho g L^2$

34. Water flows through a horizontal pipe of varying cross-section at a rate of $0.314 \text{ m}^3 \text{ s}^{-1}$. The velocity of water at a point where the radius of the pipe is 10 cm is
- (A) 0.1 ms^{-1} (B) 1 ms^{-1}
 (C) 10 ms^{-1} (D) 100 ms^{-1}

35. A solid cube of mass m at a temperature θ_0 is heated at a constant rate. It becomes liquid at temperature θ_1 and vapour at temperature θ_2 . Let s_1 and s_2 be specific heats in its solid and liquid states respectively. If L_f and L_v are latent heats of fusion and vaporisation respectively, then the minimum heat energy supplied to the cube until it vaporises is

- (A) $ms_1(\theta_1 - \theta_0) + ms_2(\theta_2 - \theta_1)$
 (B) $mL_f + ms_2(\theta_2 - \theta_1) + mL_v$
 (C) $ms_1(\theta_1 - \theta_0) + mL_f + ms_2(\theta_2 - \theta_1) + mL_v$
 (D) $ms_1(\theta_1 - \theta_0) + mL_f + ms_2(\theta_2 - \theta_0) + mL_v$
36. One mole of an ideal monoatomic gas is taken round the cyclic process MNOM. The work done by the gas is

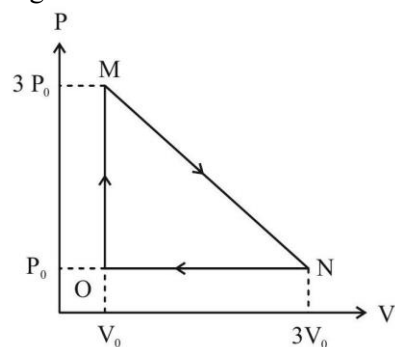

- (A) $4.5 P_0 V_0$ (B) $4 P_0 V_0$
 (C) $9 P_0 V_0$ (D) $2 P_0 V_0$
37. The ratio of molar specific heats of oxygen is
- (A) 1.4 (B) 1.67
 (C) 1.33 (D) 1.28
38. For a particle executing simple harmonic motion (SHM), at its mean position
- (A) Velocity is zero and acceleration is maximum
 (B) Velocity is maximum and acceleration is zero
 (C) Both velocity and acceleration are maximum
 (D) Both velocity and acceleration are zero
39. A motor-cyclist moving towards a huge cliff with a speed of 18 kmh^{-1} , blows a horn of source frequency 325 Hz . If the speed of the sound in air is 330 ms^{-1} , the number of beats heard by him is
- (A) 5 (B) 4
 (C) 10 (D) 7
40. A body has a charge of $-3.2 \mu\text{C}$. The number of excess electrons it has is
- (A) 5.12×10^{25} (B) 5×10^{12}
 (C) 2×10^{13} (D) 5.12×10^{13}



41. A point of charge A of $+10\mu\text{C}$ and another point charge B of $+20\mu\text{C}$ are kept 1 m apart in free space. The electrostatic force on A due to B is \vec{F}_1 and the electrostatic force on B due to A is \vec{F}_2 . Then

(A) $\vec{F}_1 = -2\vec{F}_2$ (B) $\vec{F}_1 = -\vec{F}_2$
 (C) $2\vec{F}_1 = -\vec{F}_2$ (D) $\vec{F}_1 = \vec{F}_2$

42. A uniform electric field $E = 3 \times 10^5 \text{ NC}^{-1}$ is acting along the positive Y-axis. The electric flux through a rectangle of area $10 \text{ cm} \times 30 \text{ cm}$ whose plane is parallel to the Z-X plane is
- (A) $12 \times 10^3 \text{ Vm}$ (B) $9 \times 10^3 \text{ Vm}$
 (C) $15 \times 10^3 \text{ Vm}$ (D) $18 \times 10^3 \text{ Vm}$

43. The total electric flux through a closed spherical surface of radius 'r' enclosing an electric dipole of dipole moment $2aq$ is (Given $\epsilon_0 =$ permittivity of free space)

(A) Zero (B) $\frac{q}{\epsilon_0}$
 (C) $\frac{2q}{\epsilon_0}$ (D) $\frac{8\pi r^2 q}{\epsilon_0}$

44. Under electrostatic condition of a charged conductor, which among the following statements is true?

- (A) The electric field on the surface of a charged conductor is $\frac{\sigma}{2\epsilon_0}$, where σ is the surface charge density
 (B) The electric potential inside a charged conductor is always zero
 (C) Any excess charge resides on the surface of the conductor
 (D) The net electric field is tangential to the surface of the conductor

45. A cube of side 1 cm contains 100 molecules each having an induced dipole moment of $0.2 \times 10^{-6} \text{ C-m}$ in an external electric field of 4NC^{-1} . The electric susceptibility of the material is $\text{C}^2 \text{ N}^{-1} \text{ m}^{-2}$.

(A) 50 (B) 5
 (C) 0.5 (D) 0.05

46. A capacitor of capacitance $5\mu\text{F}$ is charged by a battery of emf 10 V. At an instant of time, the potential difference across the capacitor is 4 V and the time rate of change of potential difference across the capacitor is 0.6V s^{-1} . Then the time rate at which energy is stored in the capacitor at that instant is

(A) $12\mu\text{W}$ (B) $3\mu\text{W}$
 (C) Zero (D) $30\mu\text{W}$

47. \vec{E} is the electric field inside a conductor whose material has conductivity σ and resistivity ρ . The current density inside the conductor is \vec{j} . The correct form of Ohm's law is

(A) $\vec{E} = \sigma\vec{j}$ (B) $\vec{j} = \rho\vec{E}$
 (C) $\vec{E} = \rho\vec{j}$ (D) $\vec{E} \cdot \vec{j} = \rho$

48. In the circuit shown, the end A is at potential V_0 and end B is grounded. The electric current I indicated in the circuit is

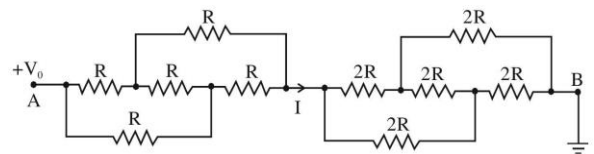

(A) $\frac{V_0}{R}$ (B) $\frac{2V_0}{R}$
 (C) $\frac{3V_0}{R}$ (D) $\frac{V_0}{3R}$

49. The electric current flowing through a given conductor varies with time as shown in the graph below. The number of free electrons which flow through a given cross-section of the conductor in the time interval $0 \leq t \leq 20 \text{ s}$ is

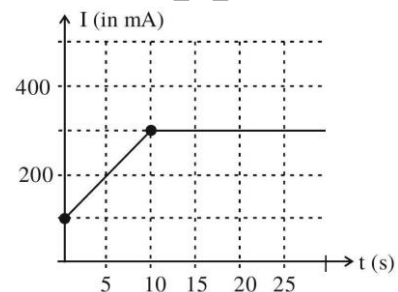

(A) 3.125×10^{19} (B) 1.6×10^{19}
 (C) 6.25×10^{18} (D) 1.625×10^{18}

50. The I-V graph for a conductor at two different temperatures 100°C and 400°C is as shown in the figure. The temperature coefficient of resistance of the conductor is about (in per degree Celsius)

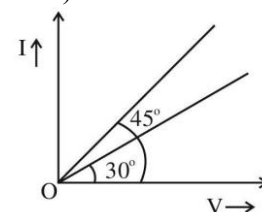

(A) 3×10^{-3} (B) 6×10^{-3}
 (C) 9×10^{-3} (D) 12×10^{-3}



51. An electric bulb of 60 W, 120 V is to be connected to 220 V source. What resistance should be connected in series with the bulb, so that the bulb glows properly?

- (A) 50Ω (B) 100Ω
(C) 200Ω (D) 288Ω

52. In an experiment to determine the temperature coefficient of resistance of a conductor, a coil of wire X is immersed in a liquid. It is heated by an external agent. A meter bridge set up is used to determine resistance of the coil X at different temperatures. The balancing points measured at temperatures $t_1 = 0^\circ\text{C}$ and $t_2 = 100^\circ\text{C}$ are 50 cm and 60 cm respectively. If the standard resistance taken out is $S = 4\Omega$. in both trials, the temperature coefficient of the coil is

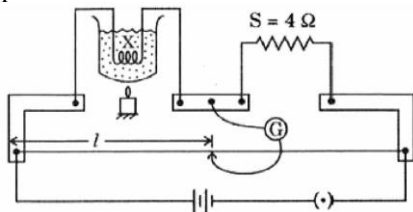

- (A) 0.05°C^{-1} (B) 0.02°C^{-1}
(C) 0.005°C^{-1} (D) 2.0°C^{-1}

53. A moving electron produces

- (A) only electric field
(B) both electric and magnetic field
(C) only magnetic field
(D) neither electric nor magnetic field

54. A coil having 9 turns carrying a current produces magnetic field B_1 at the centre. Now the coil is rewound into 3 turns carrying same current. Then the magnetic field at the centre $B_2 =$ _____

- (A) $\frac{B_1}{9}$ (B) $9B_1$
(C) $3B_1$ (D) $\frac{B_1}{3}$

55. A particle of specific charge $\frac{q}{m} = \pi Ck\text{g}^{-1}$ is projected from the origin towards positive x -axis with the velocity 10 ms^{-1} in a uniform magnetic field $\vec{B} = -2\hat{k}\text{T}$. The velocity \vec{v} particle after time $t = \frac{1}{12}\text{ s}$ will be (in ms^{-1})

- (A) $5(\hat{i} + \hat{j})$ (B) $5(\hat{i} + \sqrt{3}\hat{j})$
(C) $5(\sqrt{3}\hat{i} - \hat{j})$ (D) $5(\sqrt{3}\hat{i} + \hat{j})$

56. The magnetic field at the centre of a circular coil of radius R carrying current I is 64 times the magnetic field at a distance x on its axis from the centre of the coil. Then the value of x is

- (A) $\frac{R}{4}\sqrt{15}$ (B) $R\sqrt{3}$
(C) $\frac{R}{4}$ (D) $R\sqrt{15}$

57. Magnetic hysteresis is exhibited by _____ magnetic materials.

- (A) only para (B) only dia
(C) only ferro (D) both para and ferro

58. Magnetic susceptibility of Mg at 300 K is 1.2×10^{-5} . What is its susceptibility at 200 K ?

- (A) 18×10^{-5} (B) 180×10^{-5}
(C) 1.8×10^{-5} (D) 0.18×10^{-5}

59. A uniform magnetic field of strength $B = 2\text{mT}$ exists vertically downwards. These magnetic field lines pass through a closed surface as shown in the figure. The closed surface consists of a hemisphere S_1 a right circular cone S_2 and a circular surface S_3 . The magnetic flux through S_1 and S_2 are respectively

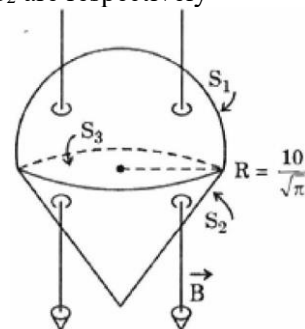

- (A) $\phi_{S_1} = -20\mu\text{ Wb}, \phi_{S_2} = +20\mu\text{ Wb}$
(B) $\phi_{S_1} = +20\mu\text{ Wb}, \phi_{S_2} = -20\mu\text{ Wb}$
(C) $\phi_{S_1} = -40\mu\text{ Wb}, \phi_{S_2} = +40\mu\text{ Wb}$
(D) $\phi_{S_1} = +40\mu\text{ Wb}, \phi_{S_2} = -40\mu\text{ Wb}$

60. In the figure, a conducting ring of certain resistance is falling towards a current carrying straight long conductor. The ring and conductor are in the same plane. Then the

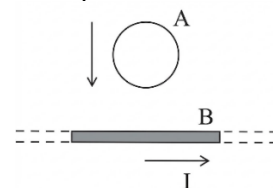

- (A) Induced electric current is zero
(B) Induced electric current is anticlockwise
(C) Induced electric current is clockwise
(D) Ring will come to rest