

*[Handwritten Signature]*

Test Booklet No.

**KAILASH**

110553454

Test Booklet Code

**12**

Do not open this Test Booklet until you are asked to do so.  
This Booklet contains 32 pages, including Rough Pages.



**ENGLISH**

**Important Instructions :**

1. The Answer Sheet is inside this Test Booklet. When you are directed to open the Test Booklet, take out the Answer Sheet and fill in the particulars on ORIGINAL Copy carefully with **blue/black** ball point pen only.
2. The test is of **3 hours** duration and the Test Booklet contains **180** multiple-choice questions (**4** options with a single correct answer) from **Physics, Chemistry and Biology (Botany and Zoology)**.
3. Wherever the symbols/constants are not mentioned, they are to be considered as per their standard meaning/value.
4. Each question carries **4** marks. For each correct response, the candidate will get **4** marks. For each incorrect response, **one** mark will be deducted from the total scores. **The maximum marks are 720.**
5. Use **Blue/Black Ball Point Pen** only for writing particulars on this page/markings responses on the Answer Sheet.
6. Rough work is to be done in the space provided for this purpose in the Test Booklet only.
7. On completion of the test, the candidate **must hand over the Answer Sheet (ORIGINAL and OFFICE Copy) to the Invigilator** before leaving the Room/Hall. The candidates are allowed to take away this Test Booklet with them.
8. **The CODE for this Booklet is "12". Make sure to enter this Booklet code in the OMR Answer Sheet.**

9. The candidates should ensure that the Answer Sheet is not folded. Do not make any stray marks on the Answer Sheet. Do not write your Roll No. anywhere else except in the specified space in the Test Booklet/Answer Sheet.
10. Use of white fluid for correction is **not** permissible on the Answer Sheet.
11. Each candidate must show on demand his/her Admit Card to the Invigilator.
12. No candidate, without special permission of the Centre Superintendent or Invigilator, should leave his/her seat.
13. The candidates should not leave the Examination Hall without handing over their Answer Sheet to the Invigilator on duty and sign (with time) the Attendance Sheet **twice. Cases, where a candidate has not signed the Attendance Sheet a second time, will be deemed not to have handed over the Answer Sheet and dealt with as an Unfair Means case.**
14. Use of Electronic/Manual Calculator is prohibited.
15. The candidates are governed by all Rules and Regulations of the examination with regard to their conduct in the Examination Room/Hall. All cases of unfair means will be dealt with as per the Rules and Regulations of this examination along with Public Examinations (Prevention of Unfair Means) Act, 2024.
16. **No part of the Test Booklet and Answer Sheet shall be detached under any circumstances.**
17. The candidates will write the Correct Test Booklet Code as given in the Test Booklet/Answer Sheet in the Attendance Sheet.
18. If a candidate marks more than one answer for a question in the **OMR Answer Sheet**, it will be treated as incorrect and negative marking will be applicable.

Name of the Candidate (in Capitals) : GAYATRI GANAPATI LAKKU

Roll Number : in figures 2712317134

: in words Two, seven, one, two, three, one, seven, one, three,

Centre of Examination (in Capitals) : \_\_\_\_\_

Candidate's Signature : [Signature] Invigilator's Signature : \_\_\_\_\_

Facsimile signature stamp of Centre Superintendent : \_\_\_\_\_

$n = 100$   
 $\Sigma = \text{sum}$   
 $\frac{u \text{ on } i}{2R}$

1. A 100-turn closely wound circular coil of radius 5 cm has a magnetic field of  $3.14 \times 10^{-3}$  T at its centre. The current flowing through the coil, and the magnitude of the magnetic moment of this coil are, respectively :

(Take  $\mu_0 = 4\pi \times 10^{-7}$  T m/A)

- (1) 2.5 A, 2 A m<sup>2</sup>      (2) 2.5 A, 20 A m<sup>2</sup>  
 (3) 2 A, 4 A m<sup>2</sup>      (4) 2 A, 10 A m<sup>2</sup>

2. Match List I with List II :

**List I**

**List II**

- A.  $E = hv$       I. de Broglie wavelength  
 B. Diffraction and Interference      II. Particle nature of light  
 C.  $\lambda = h/p$       III. Wave nature of light  
 D. Compton effect      IV. Energy of photon

Choose the correct answer from the options given below :

- (1) A-IV, B-III, C-I, D-II  
 (2) A-I, B-IV, C-III, D-II  
 (3) A-IV, B-I, C-II, D-III  
 (4) A-IV, B-III, C-II, D-I

3. The current I in the circuit shown below is :

(All diodes are ideal and identical)

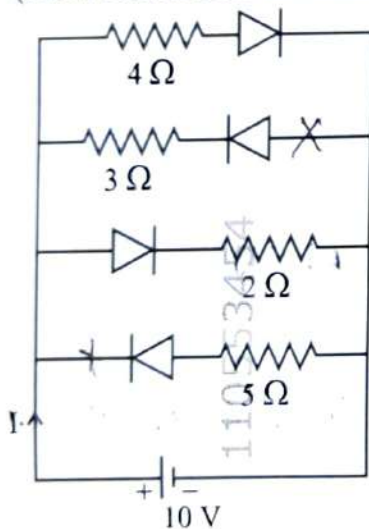

Handwritten calculations:  
 $\frac{4 \times 3}{4+3} = \frac{12 \times 2}{7}$   
 $\frac{4 \times 2}{4+2} = \frac{8}{3}$   
 $\frac{4}{7}$   
 $\frac{12+14}{7} = \frac{26}{7}$   
 $\frac{26}{7} \times \frac{1}{2} = \frac{13}{7}$   
 $\frac{13}{7} \times 10 = \frac{130}{7}$

- (1)  $\frac{5}{3}$  A      (2)  $\frac{15}{2}$  A  
 (3)  $\frac{1}{3}$  A      (4)  $\frac{5}{9}$  A

4. The speed of light in vacuum is taken as unity. If light takes 6 min 40 s to reach the Earth from the Sun, the distance between the Sun and the Earth in new unit is :

- (1)  $3 \times 10^8$       (2)  $3 \times 10^{10}$   
 (3) 400      (4) 500

5. The following plots show variation of velocity (v) with time (t), of a ball thrown vertically upward, and falling back. Which of the following plots is/are correct ?

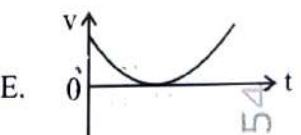
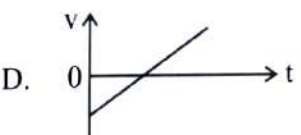
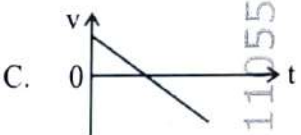
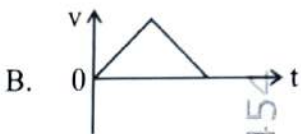
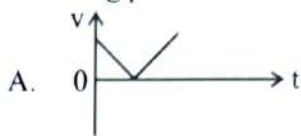

- (1) C only      (2) A and E only  
 (3) D only      (4) B only

6. In a vernier callipers, 20 VSD coincide with 16 MSD (each division of length 1 mm). The least count of the vernier callipers is :

- (1) 0.01 cm      (2) 0.1 cm  
 (3) 0.02 cm      (4) 0.2 cm

7. An ac circuit contains a resistance of  $1\text{ k}\Omega$ , a capacitor of  $0.1\text{ }\mu\text{F}$  and an inductor of  $1\text{ mH}$  connected in series. The resonance frequency of the circuit is approximately :

- (1)  $10.1\text{ kHz}$                       (2)  $20.7\text{ kHz}$   
 (3)  $15.9\text{ kHz}$                       (4)  $13.5\text{ kHz}$

8. The figure given below shows a long straight solid wire of circular cross-section of radius 'a' carrying steady current  $I$ . The current  $I$  is uniformly distributed across its cross-section. The plot which correctly represents the variation of magnetic field ( $B$ ) with distance ( $r$ ) from the axis of the conductor in the region is :

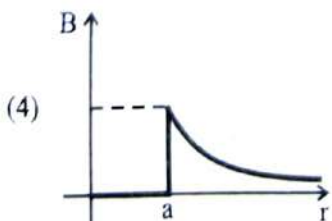
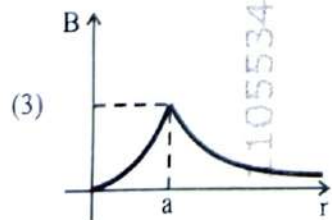
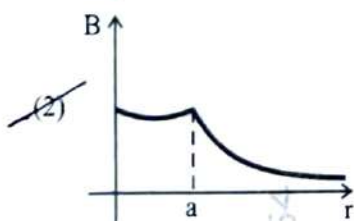
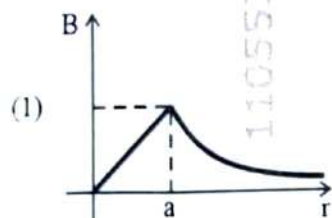
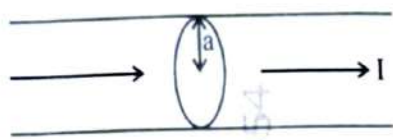

9. A uniform metallic wire having resistance  $4\text{ }\Omega$  is bent to form a square loop (ABCD) (see figure). A resistance of  $2\text{ }\Omega$  is connected between points B and D and a battery of  $2\text{ V}$  is connected across points A and C as shown in the figure. Now the value of current ( $I$ ) is :

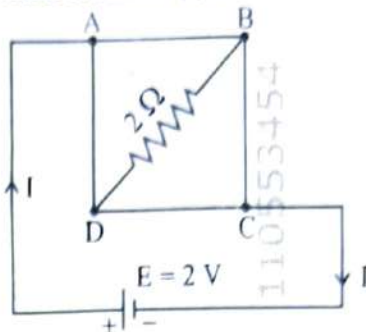

- (1)  $2\text{ A}$                       ~~(2)  $4\text{ A}$~~   
 (3)  $8\text{ A}$                       (4)  $4.5\text{ A}$

10. An unknown nucleus has a nuclear density of  $2.29 \times 10^{17}\text{ kg/m}^3$  and mass of  $19.926 \times 10^{-27}\text{ kg}$ . Its mass number  $A$  is approximately :

(Take  $R_0 = 1.2 \times 10^{-15}\text{ m}$ ,  $4\pi = 12.56$ )

- (1)  $12$                       (2)  $19$   
 (3)  $20$                       (4)  $16$

11. A rectangular wire loop of sides  $8\text{ cm}$  and  $3\text{ cm}$  with a small cut, is moving out of a region of uniform magnetic field of magnitude  $0.3\text{ T}$  directed normal to the plane of the loop. The emf developed across the cut, if the velocity of the loop is  $2\text{ cm s}^{-1}$ , in a direction normal to the shorter side of the loop, will be :

- (1)  $1.8 \times 10^{-4}\text{ volt}$                       (2)  $1.2 \times 10^{-4}\text{ volt}$   
 (3)  $1.3 \times 10^{-4}\text{ volt}$                       (4)  $4.8 \times 10^{-4}\text{ volt}$

12. A galvanometer of resistance  $100\text{ }\Omega$  gives full scale deflection for a current of  $1\text{ mA}$ . It is converted into an ammeter of range  $0 - 10\text{ A}$ . The shunt required is :

- (1)  $0.01\text{ }\Omega$                       (2)  $0.10\text{ }\Omega$   
 (3)  $0.001\text{ }\Omega$                       (4)  $1.0\text{ }\Omega$

13. In Young's double slit experiment, using monochromatic light of wavelength  $\lambda$ , the intensity of light at a point on the screen where the path difference is  $\lambda$  is  $K$  units. The intensity of light at a point where the path difference is  $\frac{\lambda}{3}$  will be :

- (1)  $\frac{K}{4}$                       (2)  $K$   
 (3)  $\frac{K}{2}$                       (4)  $2K$

14. The magnitude and direction of the acceleration produced in a body of mass 5 kg when two mutually perpendicular forces 8 N and 6 N act on it, are respectively :

- (1)  $2 \text{ m s}^{-2}$ ;  $\tan^{-1}(3/4)$  with 6 N force  
 (2)  $2 \text{ m s}^{-2}$ ;  $\tan^{-1}(4/3)$  with 8 N force  
 (3)  $2 \text{ m s}^{-2}$ ;  $\tan^{-1}(3/4)$  with 8 N force  
 (4)  $20 \text{ m s}^{-2}$ ;  $\tan^{-1}(4/3)$  with 8 N force

15. Five capacitors of capacitances

$C_1 = C_2 = C_3 = C_4 = 10 \mu\text{F}$  and  $C_5 = 2.5 \mu\text{F}$  are connected as shown, along with a battery of 50 V.

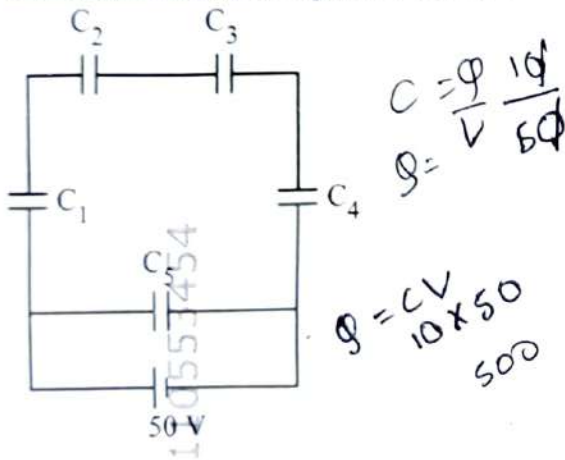

The equivalent capacitance and the charges on each capacitor respectively are :

- (1)  $5 \mu\text{F}$ ,  $125 \mu\text{C}$  on all capacitors  
 (2)  $5 \mu\text{F}$ ,  $250 \mu\text{C}$  on all capacitors  
 (3)  $4 \mu\text{F}$ ,  $250 \mu\text{C}$  on  $C_1$  to  $C_4$  and  $125 \mu\text{C}$  on  $C_5$   
 (4)  $5 \mu\text{F}$ ,  $125 \mu\text{C}$  on  $C_1$  to  $C_4$  and  $25 \mu\text{C}$  on  $C_5$

16. In a metre bridge experiment (see figure), the positions of the cell, E, and galvanometer, G, are interchanged. We shall observe in the galvanometer :

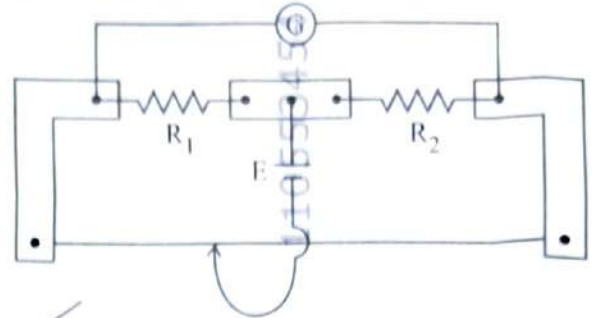

- (1) Only the right-sided deflection  
 (2) Only the left-sided deflection  
 (3) There will be no deflection irrespective of the position of the jockey  
 (4) Both right-sided and left-sided deflection and at balance point, no deflection

17. The power of a crane, which lifts a mass of 1000 kg to a height of 20 m in 10 s is : ( $g = 9.8 \text{ m/s}^2$ )

- (1) 19.6 W                      (2) 39.2 W  
 (3) 39.2 kW                      (4) 19.6 kW

18. Match List I with List II :

List I	List II
A. Young's Modulus	I. $\frac{\Delta d}{\Delta L} \left( \frac{L}{d} \right)$
B. Compressibility	II. $\frac{FL}{A(\Delta L)}$
C. Bulk Modulus	III. $-\frac{1}{\Delta P} \left( \frac{\Delta V}{V} \right)$
D. Poisson's Ratio	IV. $-P \left( \frac{V}{\Delta V} \right)$

Choose the **correct** answer from the options given below :

- (1) A-I, B-IV, C-III, D-II  
 (2) A-IV, B-I, C-II, D-III  
 (3) A-III, B-II, C-I, D-IV  
 (4) A-II, B-III, C-IV, D-I

19. In a concave lens, a ray of light emanating from the object parallel to the principal axis of the lens, after refraction :

- (1) emerges parallel to the principal axis.
- (2) appears to diverge from the first principal focus.
- (3) passes through  $2F$ , which is the radius of curvature of the lens.
- (4) passes through the second principal focus.

20. A thin wire of length 'L' and linear mass density 'm' is bent into a circular ring (in x-y plane) with centre 'C' as shown in figure. The moment of inertia of the ring about an axis yy' will be :

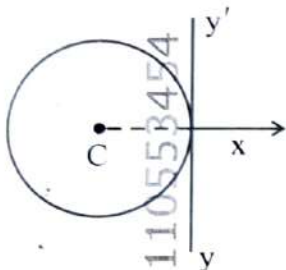

- (1)  $\frac{3 mL^3}{8 \pi^2}$
- (2)  $\frac{3 mL^3}{8 \pi}$
- (3)  $\frac{3 mL^2}{8 \pi^2}$
- (4)  $\frac{3 mL^2}{8 \pi}$

21. Each side of a metallic cube of mass 5.580 kg is measured to be 9.0 cm. Keeping the significant figures in view, the density of the material of the cube can be best expressed as  $X \times 10^3 \text{ kg m}^{-3}$ , where the value of X is :

- (1) 7.654
- (2) 7.7
- (3) 7.65
- (4) 7.6

22. For a travelling harmonic wave  $y(x, t) = 2.0 \cos 2\pi(10t - 0.0080x + 0.35)$ , where x and y are in cm and t in s. The phase difference between oscillatory motion of two points separated by a distance of 0.5 m is :

- (1)  $8 \pi \text{ rad}$
- (2)  $0.08 \pi \text{ rad}$
- (3)  $0.008 \pi \text{ rad}$
- (4)  $0.8 \pi \text{ rad}$

23. A ray of monochromatic light is passing through an equilateral prism (ABC) as shown in the figure. The refracted ray (QR) is parallel to its base (BC) and the angle of incidence (i) is  $50^\circ$ . Then the angle of deviation ( $\delta$ ) is :

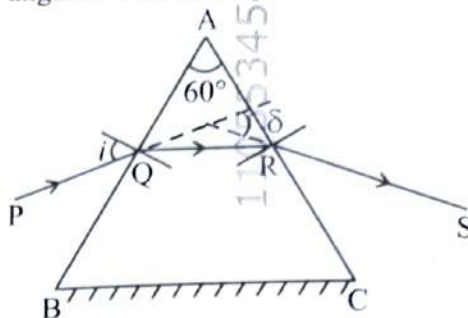

- (1)  $40^\circ$
- (2)  $45^\circ$
- (3)  $55^\circ$
- (4)  $35^\circ$

24. In the circuit shown below, the voltage appearing across the diode D will be of the form :

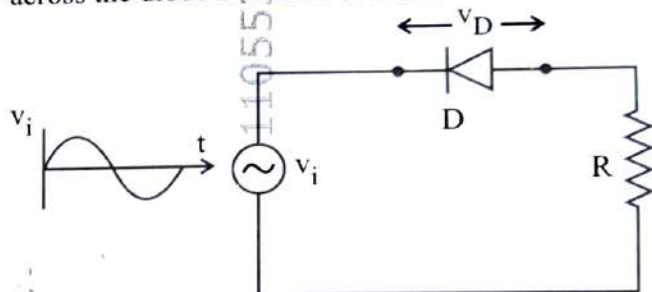

- (1)
- (2)
- (3)
- (4)

25. For a simple pendulum, having time period  $T$ , the variation of kinetic energy (K.E.) with time ( $t$ ) is represented by :

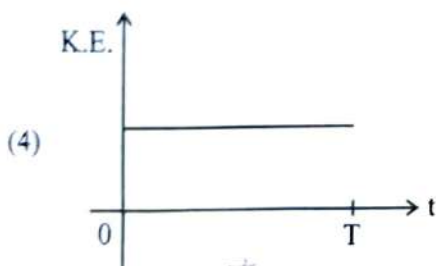
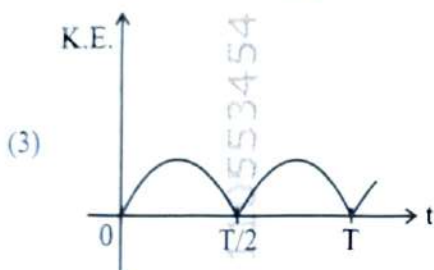
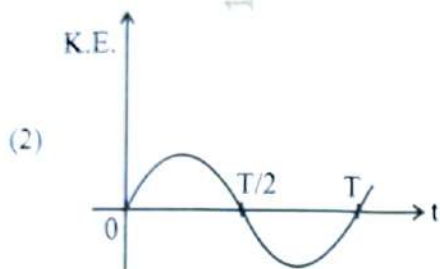
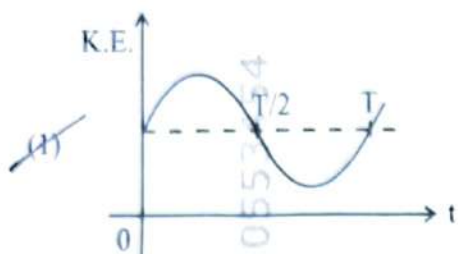

344  
x6  
-----  
374  
6x12x2

26. A resistor is connected to a battery of 12 V emf and internal resistance  $2 \Omega$ . If the current in the circuit is 0.6 A, the terminal voltage of the battery is :

(1) 10 V (2) 10.8 V (3) 12 V (4) 1.2 V

27. The amount of work done to raise a mass ' $m$ ' from the surface of the Earth to a height equal to the radius of the Earth ' $R$ ', will be :

(1)  $2 mg R$  (2)  $mg R$   
(3)  $mg \frac{R}{4}$  (4)  $mg \frac{R}{2}$

28. An electric heater supplies heat to a system at a rate of 100 W. If the system performs work at a rate of 75 J/s, then the rate at which internal energy increases will be :

(1) 125 W (2) 100 W  
(3) 25 W (4) 75 W

29. A room heater is rated 400 W, 220 V. If the supply voltage drops to 200 V, what will be the power consumed (approximately)?

(1) 121 W (2) 331 W  
(3) 200 W (4) 400 W

30. When a ruler falls vertically, 5 different persons catch it with different reaction times.

( $g = 9.8 \text{ m s}^{-2}$ )

A. Person A has reaction time of 0.20 s. <sup>3</sup>  
B. Person B has reaction time of 0.22 s. <sup>!</sup>  
C. Person C has reaction time of 0.18 s. <sup>5</sup>  
D. Person D has reaction time of 0.19 s. <sup>u</sup>  
E. Person E has reaction time of 0.21 s. <sup>2</sup>

What is the correct order of the distance travelled by the ruler for each person ?

(1) C > D > A > B > E  
(2) C > D > A > E > B  
(3) B > E > A > C > D  
(4) B > E > A > D > C

31. Consider two uncharged capacitors of equal capacitance 200 pF. One of them is charged by a 100 V supply and disconnected. Now this capacitor is connected to the uncharged capacitor. The amount of electrostatic energy lost in the process is :

(1)  $1.0 \times 10^{-6} \text{ J}$  (2)  $0.5 \times 10^{-6} \text{ J}$   
(3) 0.5 J (4) 1.0 J

32. Savitha, a XI standard student, while conducting an experiment to determine the effective length of a simple pendulum L, notes down the data of time taken to complete 30 oscillations as 60 s and hence calculates the length of the simple pendulum as :

(Take  $\pi^2 = 9.8$ , and  $g = 9.8 \text{ m/s}^2$ )

- (1) 2 m (2) 0.75 m  
(3) 1.5 m (4) 1 m

33. The peak value of an alternating current is 5 A and frequency is 60 Hz. How long will the current, starting from zero, take to reach the peak value ?

- (1)  $\frac{1}{240}$  s (2)  $\frac{1}{30}$  s  
(3)  $\frac{1}{120}$  s (4)  $\frac{1}{60}$  s

34. In interference and diffraction, the light energy is redistributed. If it reduces in one region, producing a dark fringe, it increases in another region, producing a bright fringe.

- A. As there is no gain or loss of energy, these phenomena are consistent with the principle of conservation of energy.  
B. Diffraction and interference are characteristics exhibited only by light waves.

Choose the **correct** answer from the options given below :

- (1) A is true, but B is false  
(2) A is true and B is also true  
(3) A is false, but B is true  
(4) Both A and B are false

35. A box of mass 15 kg is kept on the floor of a stationary trolley. The coefficient of static friction between the box and the trolley is 0.12. Keeping the box in stationary state over the trolley, the maximum acceleration with which the trolley can be moved horizontally in  $\text{m s}^{-2}$  is :

- ( $g = 10 \text{ m/s}^2$ )  
(1) 1.5 (2) 1.8  
(3) 2.1 (4) 1.2

36. The sum of kinetic energy and potential energy of a simple pendulum bob is 0.02 joule. The speed of the simple pendulum bob at equilibrium position is approximately :

(Consider mass of the bob = 20 g)

- (1) 1.41 m/s (2) 14.1 m/s  
(3) 0.2 m/s (4) 2.0 m/s

37. Four statements are given (A is mass number) :

- A. The volume of a nucleus is proportional to  $A^{1/3}$ .  
B. The volume of a nucleus is proportional to A.  
C. The difference in mass of an atom and its nucleus is called the mass defect.  
D. The difference in mass of a nucleus and its constituents is called the mass defect.

Choose the **correct** answer from the options given below :

- (1) B and D are true, but A and C are false  
(2) A and D are true, but B and C are false  
(3) A and C are true, but B and D are false  
(4) B and C are true, but A and D are false

38. The angular speed of a flywheel is increased from 600 rpm to 1200 rpm in 10 s. The number of revolutions completed by the flywheel during this time is :

- (1) 600 (2) 900  
(3) 300 (4) 150

39. A submarine is designed to withstand an absolute pressure of 100 atm. How deep can it go below the water surface ?

(Consider the density of water =  $1000 \text{ kg m}^{-3}$ ,  
 $1 \text{ atm} = 1 \times 10^5 \text{ Pa}$  and gravitational acceleration  
 $g = 10 \text{ m/s}^2$ )

- (1) 9900 m (2) 99 m  
(3) 9000 m (4) 990 m

40. Match List I with List II :

**List I**

(Electromagnetic wave)

A. Microwave

B. Visible light

C. Gamma rays

D. Infra-red rays

**List II**

(Production)

I. Electrons in atoms emit light when they move from a higher energy level to a lower energy level

II. Radioactive decay of nucleus

III. Vibration of atoms and molecules

IV. Klystron valve or magnetron valve

Choose the **correct** answer from the options given below :

(1) A-III, B-I, C-II, D-IV

(2) A-III, B-IV, C-I, D-II

(3) A-IV, B-III, C-II, D-I

(4) A-IV, B-I, C-II, D-III

41. Which of the following statements are correct ?

A. Inside a conductor, the electrostatic field is zero.

B. Electric field at the surface of a charged conductor does not depend on its surface charge density.

C. The interior of a charged conductor can have no excess charge in the static situation.

D. At the surface of a charged conductor, the electrostatic field must be normal to the surface at every point.

E. The electrostatic potential is zero everywhere inside a charged conductor.

Choose the **correct** answer from the options given below :

(1) C, D and E only

(2) A, B and D only

(3) A, C and D only

(4) A, C and E only

42. For a metal of work function 6.6 eV, which of the following wavelengths of incident radiation does **not** give rise to the photoelectric effect ?

(Take Planck's constant as  $6.6 \times 10^{-34}$  J s)

(1) 200 nm

(2) 150 nm

(3) 100 nm

(4) 50 nm

43. In the first excited state of hydrogen atom, the energy of its electron is -3.4 eV. The radial distance of the electron from the hydrogen nucleus in this case is approximately :

(Take  $1 \text{ eV} = 1.6 \times 10^{-19}$  J,  $e = 1.6 \times 10^{-19}$  C and

$$\frac{1}{4\pi\epsilon_0} = 9 \times 10^9 \text{ N m}^2/\text{C}^2)$$

(1)  $2.1 \times 10^{-8}$  m

(2)  $2.1 \times 10^{-11}$  m

(3)  $2.1 \times 10^{-9}$  m

(4)  $2.1 \times 10^{-10}$  m

44. Two statements are given below :

A. When the forward bias voltage across a p-n junction diode increases above a certain threshold voltage, the diode current increases significantly.

B. This current is called reverse saturation current.

Choose the **correct** answer from the options given below :

(1) Both Statements A and B are false

(2) Statement A is true, but Statement B is false

(3) Both Statements A and B are true

(4) Statement A is false, but Statement B is true

45. A flask contains argon and chlorine in the ratio of 2 : 1 by mass. The temperature of the mixture is  $27^\circ\text{C}$ . The ratio of root mean square speed of the

molecules of the two gases  $\left(\frac{v_{\text{rms}}^{\text{Ar}}}{v_{\text{rms}}^{\text{Cl}}}\right)$  is :

(Atomic mass of argon = 40.0 u and molecular mass of chlorine = 70.0 u)

(1)  $\frac{\sqrt{7}}{2}$

(2)  $\frac{7}{2}$

(3)  $\frac{7}{4}$

(4)  $\frac{2}{\sqrt{7}}$